

Enhanced Performance Loads in Slab-to-Wall Moment Connections

01/2015	(29)	E16	
March 2013			

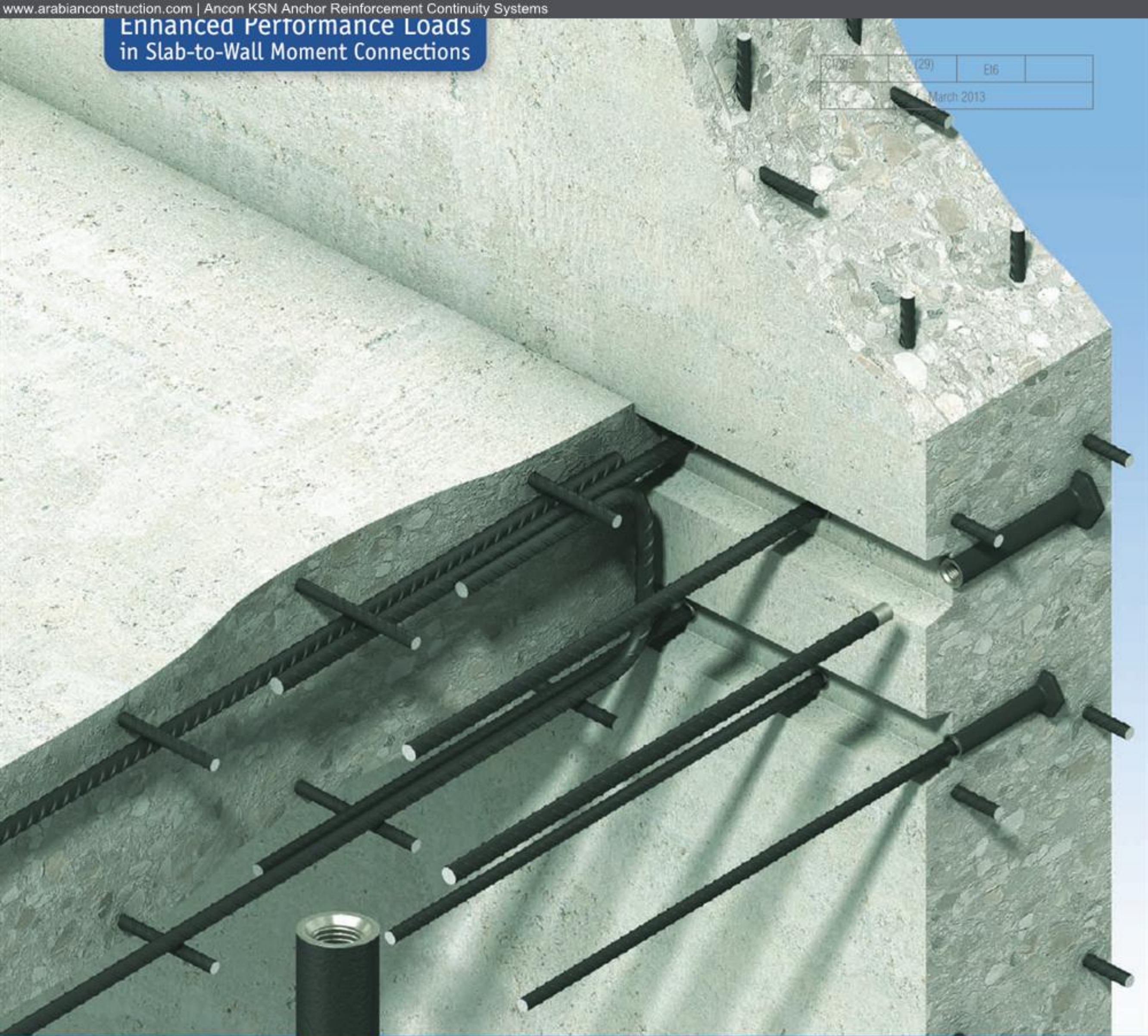

KSN Anchors
Reinforcement Continuity System
for the Construction Industry

Ancon[®]
BUILDING PRODUCTS

KSN Anchors

Safer, faster, easier construction joints

Ancon KSN Anchors, in combination with Bartec parallel-threaded reinforcing bars, simplify concrete construction joints.

Together, they allow engineers to design slab-to-wall connections without the restrictions on bar length and bar diameter of re-bend continuity systems or the awkward anchorage lengths demanded by reinforcing bar couplers.

KSN Anchors are cast into the concrete wall and, when the formwork and thread protection are removed, the reinforcing bars are simply screwed into the anchors.

This is a quicker, easier, and above all safer continuity system.

It eliminates the drilling of formwork or concrete and the dangers associated with projecting bars and on site bar straightening. It replaces hooked bars and stirrups, simplifying bar scheduling and minimising congestion in the wall.

Unlike pull-out bar systems, there is virtually no restriction on continuation bar length and they are available in a greater choice of bar diameters.

In addition to their suitability for direct tensile applications, independent tests have verified an enhancement in the performance of KSN Anchors when used in slab-to-wall moment connections.

Contents

<u>System Components, Details for Specifying and Ordering</u>	4-5
<u>System Performance, Bottom Anchorage Options</u>	6-7
<u>Key Design Considerations</u>	8
<u>Anchor Selection Examples</u>	9
<u>Direct Tensile Concrete Characteristic Loads</u>	10-11
<u>Tensile Concrete Characteristic Loads in Moment Connections</u>	12-14

<u>Design Considerations - Reinforcement Details, Bottom Anchor Design Guidance, Ductility Requirements, Corners, Shear Checks</u>	15-19
<u>Installation Procedure and Guidance on Cutting Anchor Carrier</u>	20-22
<u>Other Ancon Products</u>	23



Traditional slab-to-wall construction joint
Drilling of formwork required, projecting reinforcing bars and congestion in the wall.



Re-bend continuity system
Box dimensions restrict bar length and diameter. On-site bar straightening required.



Reinforcing bar couplers
Awkward anchorage bars. Congestion in the wall. No shear key. Individual coupler installation slows site progress.



NEW high performance, KSN Anchor system
Anchors installed in a carrier. Indented construction joint. Virtually unlimited bar length. No bending of bars required. Less congestion in the wall.



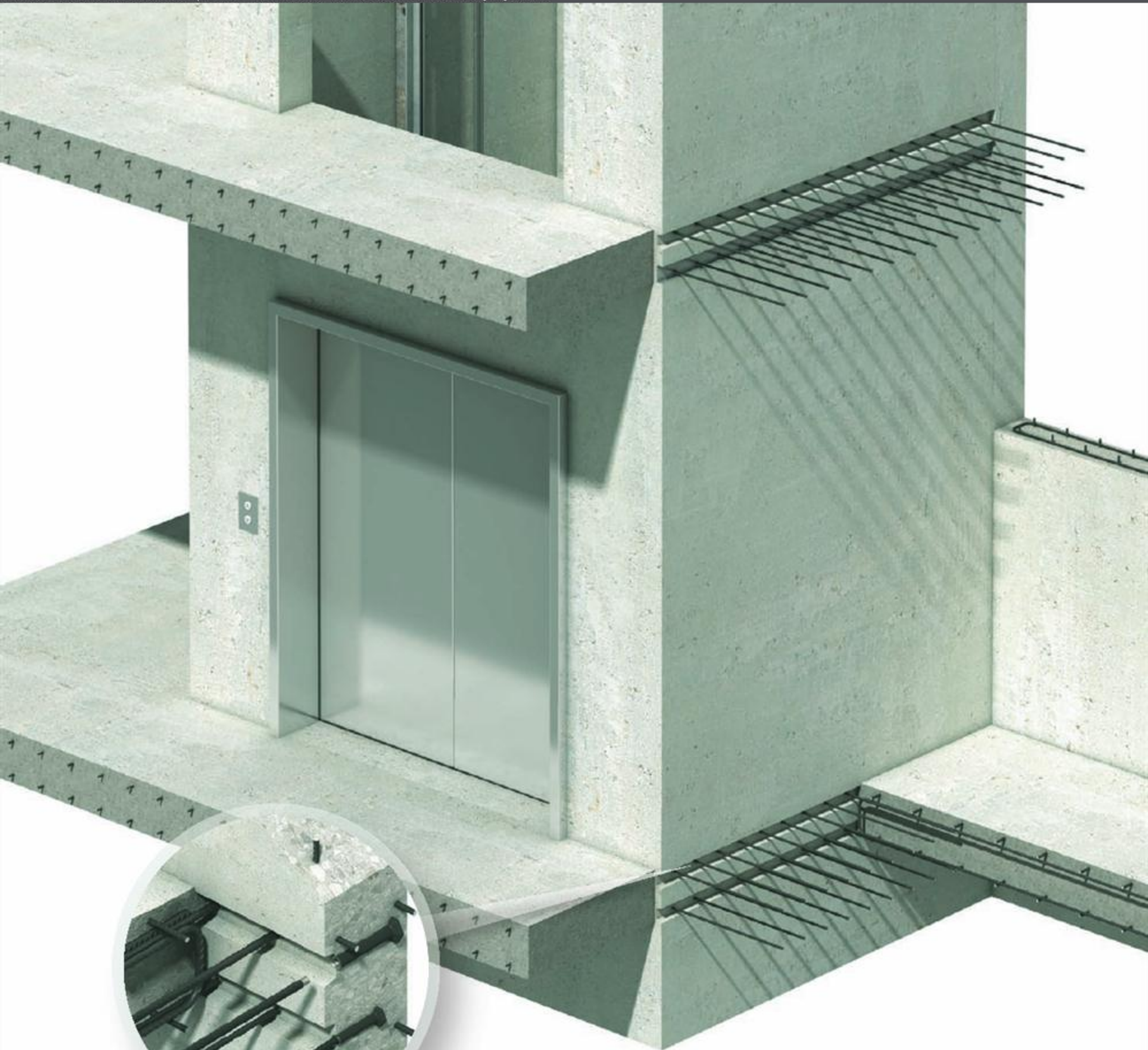

Eliminates risks associated with on-site bar straightening



Virtually unlimited continuation bar length. Suitable for EC2 lap lengths



Standard components for 'just-in-time' site delivery, direct from stock



Available up to a 20mm bar diameter. Rebind systems are restricted to Ø16mm



Simple to schedule. Fast to install



Easy visual check of correct bar engagement



No torquing required



Reduces reinforcement congestion. Ideal for thin walls



EC2 indented construction joint



Enhanced performance backed by test data



THE QUEEN'S AWARDS FOR ENTERPRISE: INNOVATION 2012



Ancon KSN Anchors

Ancon KSN Anchors, in combination with Bartec parallel-threaded reinforcing bars, simplify concrete slab-to-wall construction joints when compared to other continuity systems.

This quicker, easier and above all, safer system eliminates the need for on-site bar straightening and the drilling of formwork or concrete. The system replaces hooked anchorage bars and stirrups, thereby simplifying bar scheduling and minimising congestion in the wall. Suitable for wall thickness from 175mm.

Independent tests have verified enhancements in anchor performance in moment-resisting connections. This enhancement is specific to the KSN range.

System Components

KSN Anchors

There are eight standard anchors in the KSN range. They are manufactured from highly reliable Cr-Mo alloy steel with a minimum 15% elongation. The head is formed by hot forging to minimise material usage and improve the strength characteristics. The anchor is subsequently machined to incorporate a standard metric Bartec thread.

Independent tests have verified the direct pull out strength of these anchors (see pages 10 to 11) and also quantified the enhancement in performance of KSN Anchors when used in slab-to-wall moment connections (see pages 12 to 14).

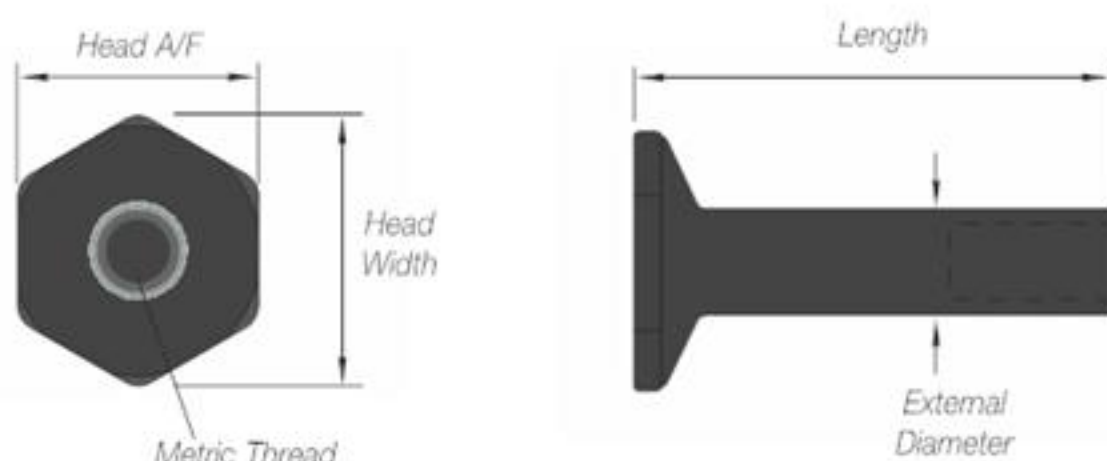

KSN Anchors, eight standard sizes available from stock

KSN Anchor Dimensions

Anchor Ref.	Nominal External Diameter (mm)	Metric Thread (mm)	Nominal Head Width (mm)	Nominal Head A/F (mm)	Anchor Length (mm)	Embedment h_{eff} mm
KSN12S	22	M16 x 2.0	46	40	115	142
KSN12M					150	177
KSN16S	28	M20 x 2.5	61	53	130	157
KSN16M					160	187
KSN16L					190	217
KSN20S	32	M24 x 3.0	75	65	150	177
KSN20M					190	217
KSN20L					230	257

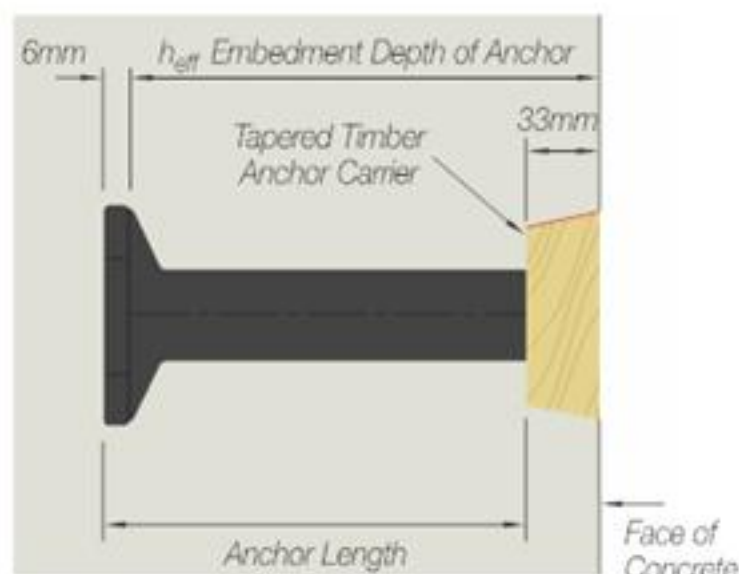

Anchor Embedment Arrangement

KSN Tapered Timber Anchor Carrier

KSN Anchors are delivered to site pre-assembled as independent rows of anchors fixed with countersunk socket head cap screws to the back of a tapered timber strip.

The timber provides an additional 33mm of embedment to each KSN Anchor and, after removal, provides a shear key for the joint. By increasing the embedment depth, the capacity of a KSN Anchor is improved.

The timber features one coloured side to denote the upward facing edge when orientating it against formwork and a product label to identify it as either a top or a bottom row of anchors. Tape is provided on the front of the strip to protect the socket head from concrete ingress to facilitate easy removal. A formwork release agent should be applied to the timber on site.



Tapered timber strips simplify installation, create a shear key and increase anchor embedment

Bartec Continuation Bars

Unlike re-bend continuity systems where bar lengths are restricted to the box dimensions, there is virtually no restriction on continuation bar length with KSN Anchors.

Ancon KSN Anchors are designed for use with 12mm, 16mm and 20mm diameter grade B500B or B500C reinforcing bar, threaded with a Bartec metric thread, supplied by Ancon. The Bartec system produces a full strength joint. The bar end is cut square and enlarged by cold forging. This increases the core diameter of the threaded portion of the bar to ensure that the strength of the bar is maintained. A parallel metric thread is cut onto the enlarged bar end. A 12mm bar is provided with an M16 thread, a 16mm bar with an M20 thread and a 20mm bar with an M24 thread.

Bar lengths to BS EN 1992:1-1 (Eurocode 2) are given in the tables below.



No on-site bar straightening required

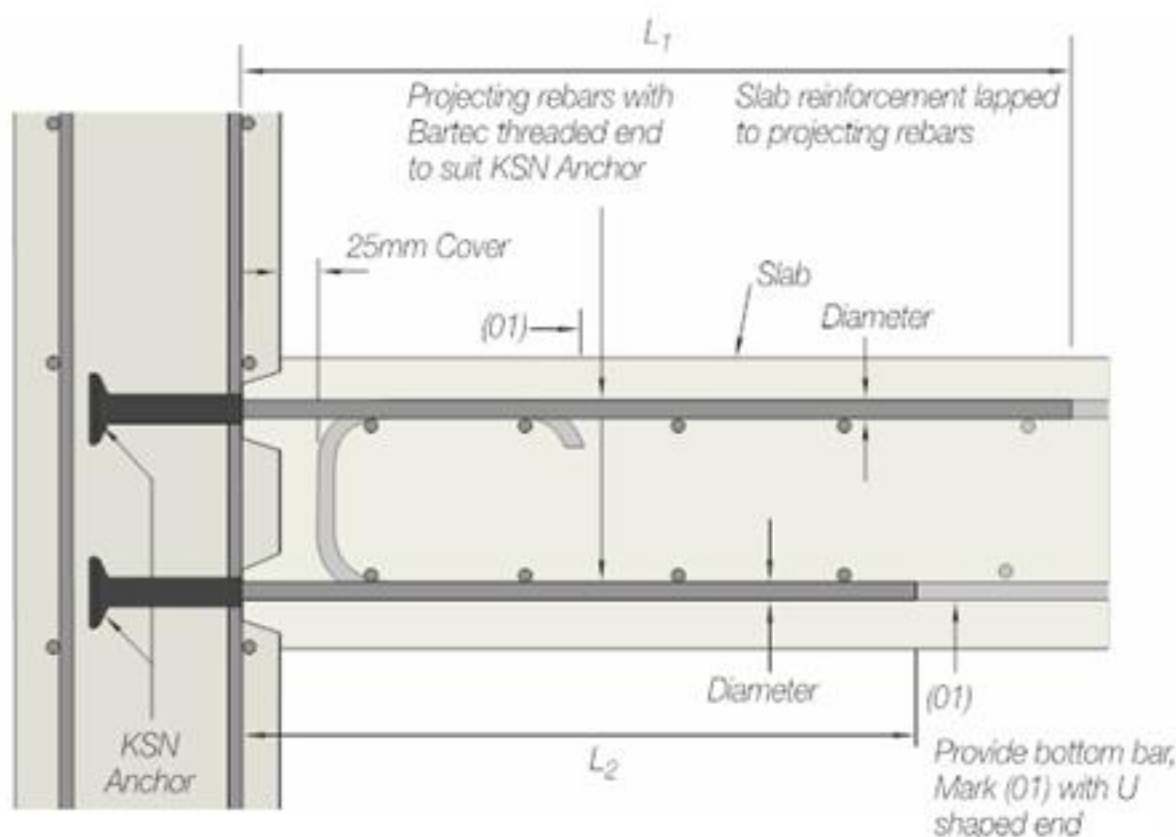

12, 16, 20mm diameter Bartec continuation bars, available in EC2 lap lengths

Top Reinforcement to Eurocode 2

Bar Diameter	Thread Size	EC2 Full Tension Lap* C32/40		Minimum Length L ₁ Required C32/40		Thread Length	Minimum Bar Length Required Good Bond	Minimum Bar Length Required Bad Bond
		Good Bond	Bad Bond	Good Bond	Bad Bond			
12	M16	630	890	688	948	16	705	965
16	M20	830	1190	888	1248	20	910	1270
20	M24	1040	1480	1098	1538	24	1125	1565

Dimensions in millimetres.

*Assumes contact lap ($\alpha_2=1$) and 100% of bar lapped at one location.

Bottom Reinforcement to Eurocode 2

Bar Diameter	Thread Size	EC2 Tension Lap* C32/40	Minimum Length L ₂ Required C32/40	Thread Length	Minimum Bar Length Required
16	M20	830	888	20	910
20	M24	1040	1098	24	1125

Dimensions in millimetres.

*Assumes contact lap ($\alpha_2=1$) and 100% of bar lapped at one location.

Refer to page 16 for bottom anchor design guidance.

Note: Good bond and bad bond conditions as defined in BS EN 1992-1-1 figure 8.2.

Specifying and Ordering

An Ancon KSN Anchor system can be specified and ordered using the following identification method:

Anchor Ref. / Horizontal Spacing (mm) / Anchor Position in Slab (TOP or BOTTOM) / Cover (mm)

e.g. KSN16S / 200 / TOP / 25

This is the reference for a KSN system comprising KSN16S anchors to be installed at 200mm horizontal spacing in the top of the slab, with 25mm cover to the reinforcement.

Ancon KSN Anchors

System Performance

Performance values for KSN Anchors are presented on pages 10 to 14 for two load applications and are based on comprehensive test data.

Direct tensile concrete characteristic loads

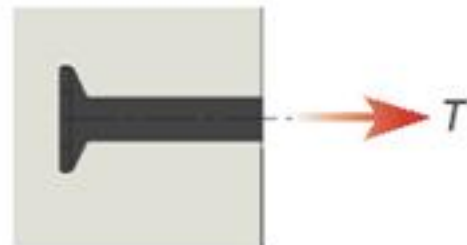

The direct pull out strength of anchors embedded in concrete has been the subject of extensive research over many years. To determine the direct pull strength of KSN Anchors, Ancon commissioned a test programme at Heriot Watt University, UK. The test results and subsequent analysis aligned closely with established formula for the pull out strength of anchors. The direct pull out strength is based on a model with a break out prism angle of approximately 35 degrees. See Fig A.

Characteristic loads as per the CEB Design of Fastenings in Concrete:

$$N_{Rk,c}^0 = k_1 \cdot f_{ck}^{0.5} \cdot h_{eff}^{1.5}$$

Where:

$N_{Rk,c}^0$ is the tension resistance of a single anchor remote from edge effects

$f_{ck}^{0.5}$ is the characteristic concrete cylinder compressive strength

h_{eff} is the embedment depth of the anchor

k_1 is an empirical coefficient

$$k_1 = 12.5$$

The equation becomes

Design resistance

$$N_{Rd,c}^0 = k_1 \cdot f_{ck}^{0.5} \cdot h_{eff}^{1.5} / \gamma_{m,c}$$

with $\gamma_{m,c} = 1.5$ as per Eurocode 2.

Anchor Spacings

Although KSN Anchors are able to provide an anchorage that is equal to or greater than the characteristic yield strength of the reinforcing bars, this is dependent on their embedment and arrangement. The capacity of the anchors is reduced when the proximity of adjacent anchors or concrete edges affect the development of the full cone, as illustrated in Fig B. Load data for reduced anchor spacing is printed in the tables on pages 10 to 14.

To achieve the maximum anchor load, the required minimum spacing is three times the depth of the anchor h_{eff} .

Fig A. Full Tensile Cone

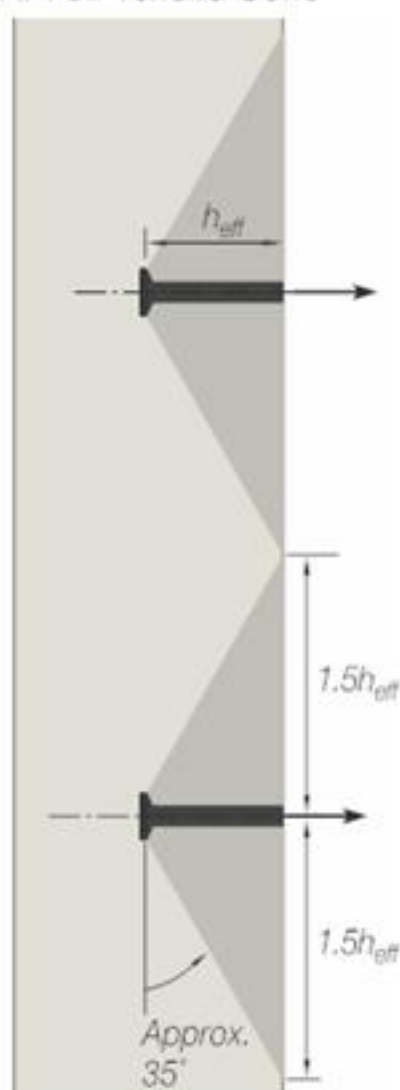
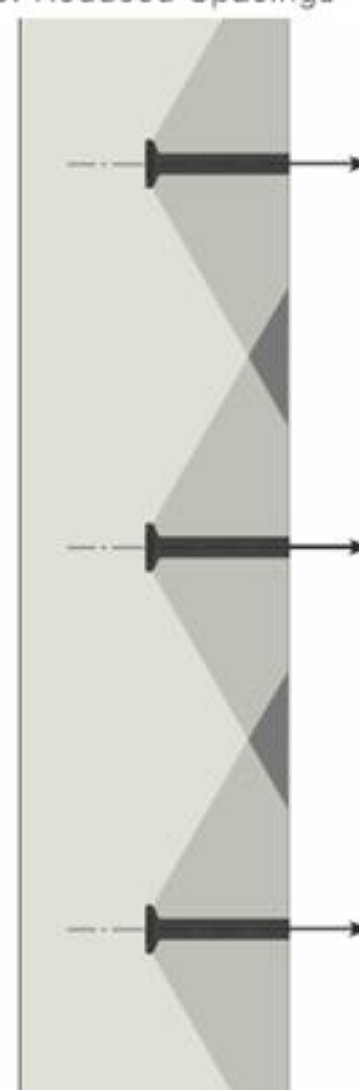
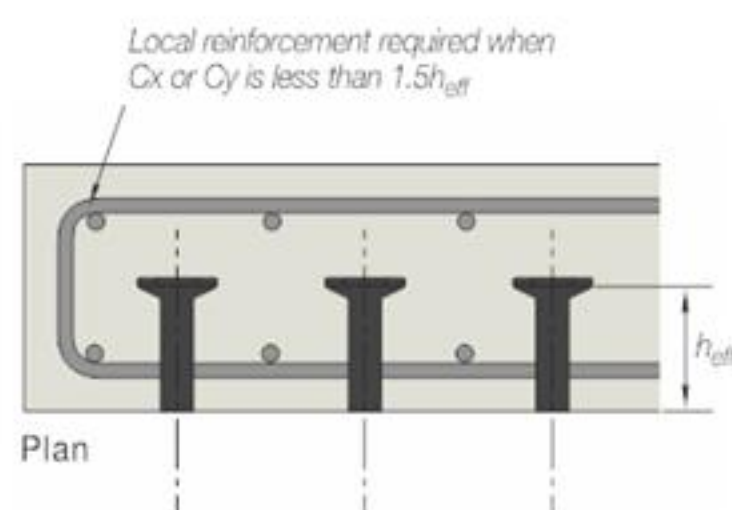
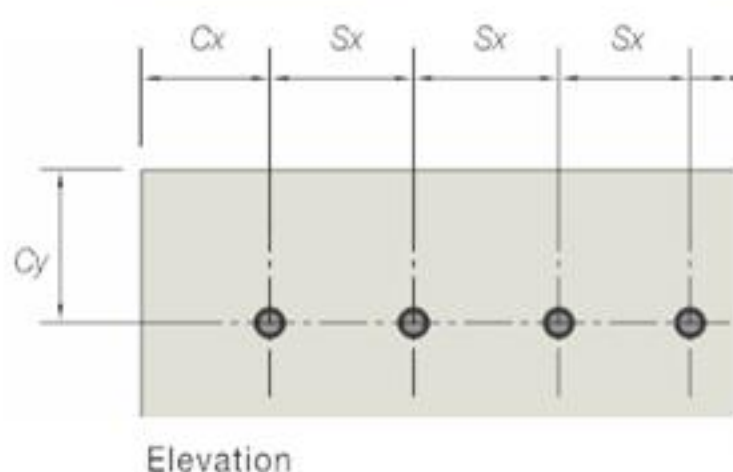

Fig B. Reduced Spacings



The tables on pages 10 to 14 assume that the close edge distances C_x and C_y are catered for by either (1) ensuring C_x and C_y are equal to or greater than $1.5 \times h_{eff}$ or (2) local reinforcement is provided (see page 15). In addition, where moment connections are used, the top of the wall shall be at least three times the effective embedment of the anchor (h_{eff}) measured from the centre line of the anchor. If these conditions cannot be met, please contact Ancon Building Products.



Tensile concrete characteristic loads in slab-to-wall moment connections

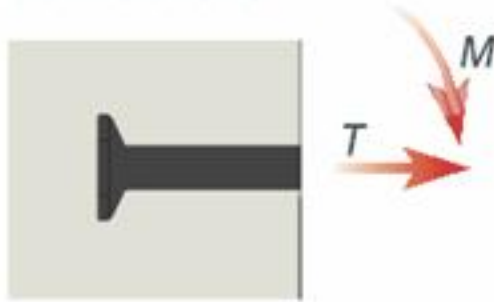

From the tests conducted to determine the direct pull out capacities of KSN Anchors (see page 6), Ancon identified a potential increase in anchor performance when the compression part of the moment couple lies within the pull out cone.

Although design procedures for the direct pull out strength of cast-in anchors are well established, existing procedures do not cover anchors within moment resisting connections, such as slab-to-wall applications. Therefore, Ancon commissioned a further series of tests at Heriot Watt University to determine the degree of enhancement in concrete cone pull out capacity in typical slab-to-wall connections and establish a design method based on the results.

The tests verified an enhancement in concrete cone capacity, when the pull out failure surface is modified by the presence of an adjacent compression force from the concrete forming part of the couple. The results showed a significant enhancement in some cases; the enhancement being strongly influenced by the ratio of the depth of the embedment of the head of the anchor to the effective depth of the anchor in the slab h_{eff}/d .

An empirical expression has been derived for the strength of KSN Anchors where the concrete cone failure is modified by an adjacent compression reaction.

Load data for KSN Anchors in moment resisting slab-to-wall connections is provided in the tables on pages 12 to 14.

The enhanced performance figures were quantified by Ancon's test programme and subsequent design procedure and are therefore specific to the KSN Anchor range.

The tests used KSN Anchors in the paired arrangement shown. The diagram illustrates how the full pull out cone is modified by an adjacent compression zone.

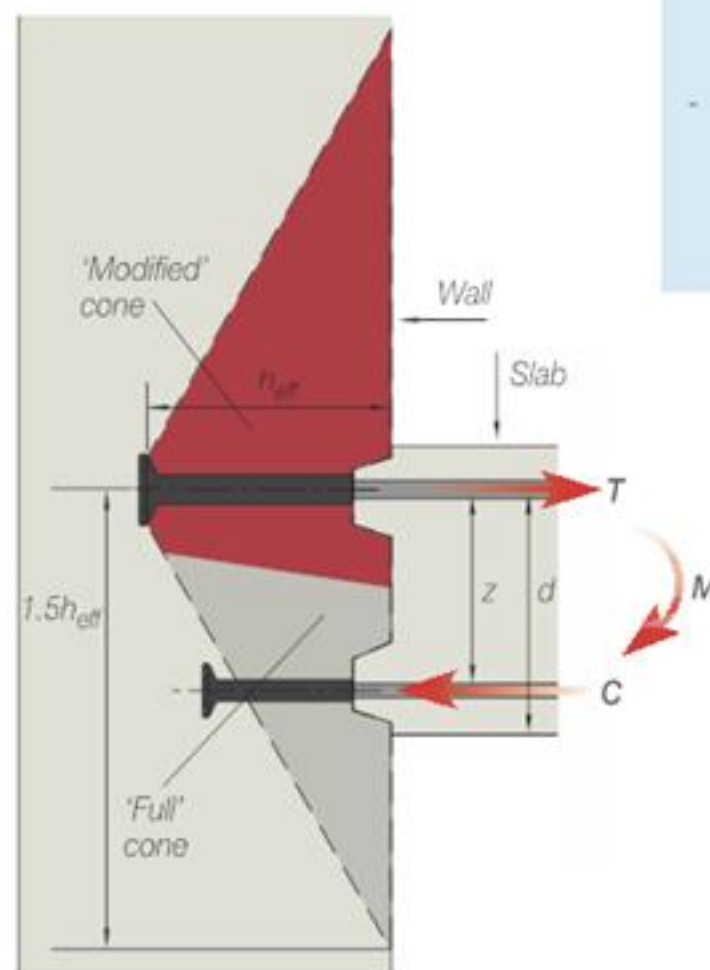

Idealised modified concrete failure. Paired arrangement used in testing.

The calculation model developed by Ancon is compatible with guidance in the following documents:

- Fib model code 2010 and fib bulletin 58 "Design of anchorages in concrete", part 3.
- ACI 318-11: Building Code Requirements for Structural Concrete, American Concrete Institute, Appendix D: Anchoring to Concrete.
- DD CEN/TS 1992-4-2:2009 Design of fastenings for use in concrete part 4-2: Headed fasteners (6.2.5)
- BS EN 1992-1-1: Eurocode 2 Design of concrete structures. Compliance with the safety concept of the code.
- DIN1045-1 Plain reinforced and prestressed concrete structures. Compliance with the safety concept of the code.

Bottom Anchorage Options

In the moment connection configuration, the tension at the joint is resisted by the top anchor and the compression by the concrete. However, part of the span bottom reinforcement needs to be anchored in the wall according to BS EN 1992:1-1 (Eurocode 2) Clause 9.3.1.2. This anchorage of bottom reinforcement may be provided using KSN Anchors, an Ancon Eazistrip reinforcement continuity system or an Ancon Coupler Box.

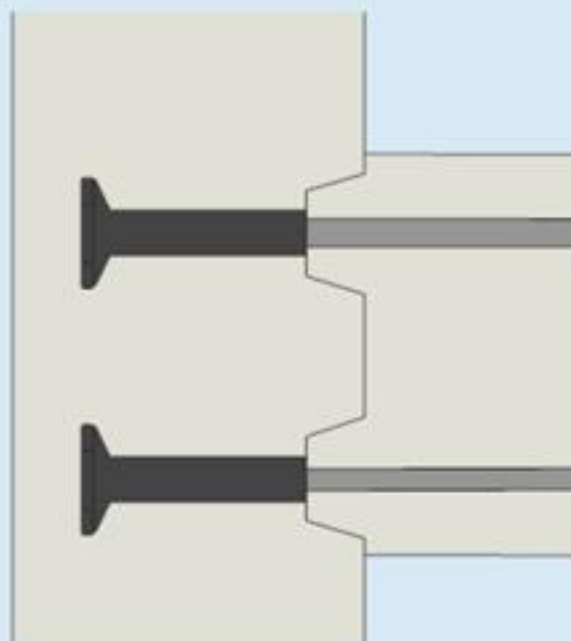

KSN Anchors at top and bottom

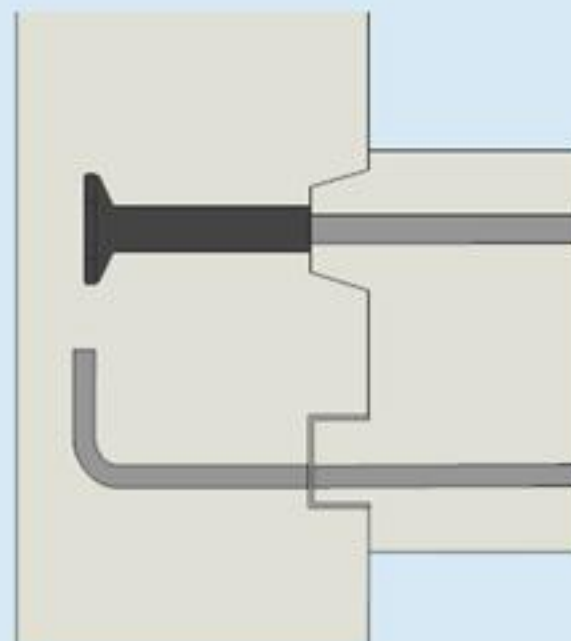

KSN Anchor at top and Eazistrip system on bottom

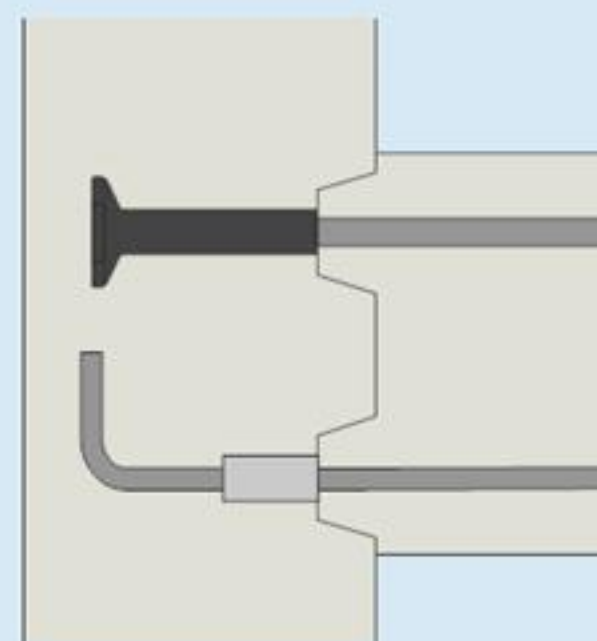

KSN Anchor at top and Bartec Coupler Box on bottom

Ancon KSN Anchors



Key Design Considerations

Effective Embedment Depth

The range of Ancon KSN Anchors, sizes 12mm to 20mm, may be used with anchor effective embedment between 75mm and 260mm.

Concrete Conditions

The structural concrete compressive strength shall be in the range C32/40 to C50/60. The tables in this brochure are based on C32/40. Please contact Ancon for other concrete grades as the capacity of the system improves with an increase in concrete strength.

The concrete in which KSN Anchors are embedded should be uncracked. This is normal for anchors embedded in walls. The minimum wall thickness is 175mm.

Moment Connections

The design procedure for moment connection assumes that the top or bottom of the wall is at least three times the effective embedment of the anchor (h_{eff}) measured from the centreline of the anchor.

Structural Analysis

The analysis of the structure should be based on the assumption of linear elastic behaviour. Plastic (yield line) methods and moment redistribution may not be used.

Shear Capacity

The shear capacity of the joint must be checked (see page 19). In tests with anchors at the top and bottom of the slab, no distress was evident that might be related to vertical shear in the plane of the face of the wall.

Seismic Applications

The anchors have not been tested in seismic conditions and therefore the design tables may overestimate the load capacity if used in seismic applications.

Design Resistance

Calculated with concrete partial material factor taken as $\gamma_c=1.5$ and steel partial material factor taken as $\gamma_s=1.15$.

Anchor Selection Examples

Design examples for KSN top anchor with standard timber carrier:

A)	Load condition:	Direct tensile load
	Wall depth:	225mm
	Wall concrete:	C32/40
	Tension applied:	175kN/m
	Slab main reinforcement spacing:	200mm c/c
	Assuming anchors at 200mm c/c :	$N_{Ed} = 175 \times 0.200 = 35\text{kN per anchor}$

From table page 10, anchors suitable for 225mm thick wall and 35kN load.

KSN12S @ 200mm c/c	Anchor design resistance $N_{Rd} = 37.4\text{kN}$
KSN12M @ 200mm c/c	Anchor design resistance $N_{Rd} = 41.8\text{kN}$
KSN16S @ 200mm c/c	Anchor design resistance $N_{Rd} = 39.4\text{kN}$
KSN16M @ 200mm c/c	Anchor design resistance $N_{Rd} = 43.0\text{kN}$
KSN20S @ 200mm c/c	Anchor design resistance $N_{Rd} = 41.8\text{kN}$

The values in the table are not in bold which means that the anchors are limited by the concrete design resistance.

Where the anchor capacity is limited by the concrete resistance, Ancon recommends the use of secondary wall reinforcement when the anchor head does not reach the wall back reinforcement (refer to page 17).

From page 17: To prevent non ductile failure without additional wall reinforcement, with wall thickness of 225mm <230mm choose KSN16M @ 200mm c/c Anchor design resistance $N_{Rd} = 43\text{kN} > N_{Ed} = 35\text{kN}$. No additional reinforcement required.

B)	Load condition:	Moment connection
	Wall depth:	225mm
	Wall concrete:	C32/40
	Slab thickness:	225mm
	Cover to top reinforcement:	25mm
	Moment applied:	$M_{Ed} = 60\text{kN.m/m}$
	Slab main reinforcement spacing:	200mm c/c
	From slab design:	$M_{Ed} = 60\text{kN.m/m}$ with $z = 182\text{mm}$
	Top anchor applied tension:	$N_{Ed} = M_{Ed}/z = 330\text{kN/m}$
	Assuming anchors at 200mm c/c	$N_{Ed} = 330 \times 0.200 = 66\text{kN per anchor.}$

From table page 12 to 14, anchors suitable for 225mm thick wall and 66kN load

KSN16S @ 200mm c/c in 225mm slab	Anchor design resistance $N_{Rd} = 85.9\text{kN}$
KSN16M @ 200mm c/c in 225mm slab	Anchor design resistance $N_{Rd} = 87.4\text{kN}$
KSN20S @ 200mm c/c in 225mm slab	Anchor design resistance $N_{Rd} = 104.5\text{kN}$

The KSN16S and KSN20S anchors are limited by the concrete design resistance (value not in bold in tables).

The KSN16M is limited by the reinforcement design resistance (value in bold).

Choose KSN16M @ 200mm c/c as the anchors are suitable for full elastic design without the need for additional reinforcement.

C)	Load condition:	Moment connection
	Wall depth:	240mm
	Wall concrete:	C32/40
	Slab thickness:	250mm
	Cover to top reinforcement:	25mm
	Moment applied:	$M_{Ed} = 95\text{kN.m/m}$
	Slab main reinforcement spacing:	200mm c/c
	From slab design:	$M_{Ed} = 95\text{kN.m}$ with $z = 202\text{mm}$
	Top anchor applied tension:	$N_{Ed} = M_{Ed}/z = 470\text{kN/m}$
	Assuming anchors at 200mm c/c	$N_{Ed} = 470 \times 0.200 = 94\text{kN per anchor.}$

From table page 12 to 14, anchors suitable for 240mm wall and 94kN

KSN20S @ 200mm c/c in 250mm slab	Anchor design resistance $N_{Rd} = 103.8\text{kN}$
----------------------------------	--

The KSN20S anchors are limited by the concrete design resistance (value not in bold in tables).

Where the anchor capacity is limited by the concrete resistance, Ancon recommends the use of secondary wall reinforcement when the anchor head does not reach the wall back reinforcement (refer to page 17).

Actual wall thickness 240mm is greater than 220mm, recommended maximum thickness without additional reinforcement.

Therefore provide 2Nr 10mm diameter links per anchor as secondary wall reinforcement to prevent non ductile failure.

Ancon KSN Anchors



Direct Tensile Concrete Design Resistance Loads

Single line of anchors in direct tension without moment:

KSN Anchors Flush with Concrete

Anchor Ref.	Rebar Dia. (mm)	Anchor Length (mm)	Minimum Wall Thickness (mm)	Embedment Depth h_{eff} (mm)	Anchor - Direct Tensile Resistance Load N_{Rd} (kN) C32/40 Concrete at Various Horizontal Spacings						
					150	200	250	300	350	400	450
KSN12S	12	115	175	109	24.6	32.8	41.0	49.2	49.2	49.2	49.2
KSN12M	12	150	175	144	28.3	37.7	47.1	49.2	49.2	49.2	49.2
KSN16S	16	130	175	124	26.2	35.0	43.7	52.5	61.2	65.1	65.1
KSN16M	16	160	185	154	29.2	39.0	48.7	58.5	68.2	78.0	87.4
KSN16L	16	190	215	184	32.0	42.6	53.3	63.9	74.6	85.3	87.4
KSN20S	20	150	175	144	28.3	37.7	47.1	56.6	66.0	75.4	81.5
KSN20M	20	190	215	184	32.0	42.6	53.3	63.9	74.6	85.3	95.9
KSN20L	20	230	255	224	35.3	47.0	58.8	70.6	82.3	94.1	105.8

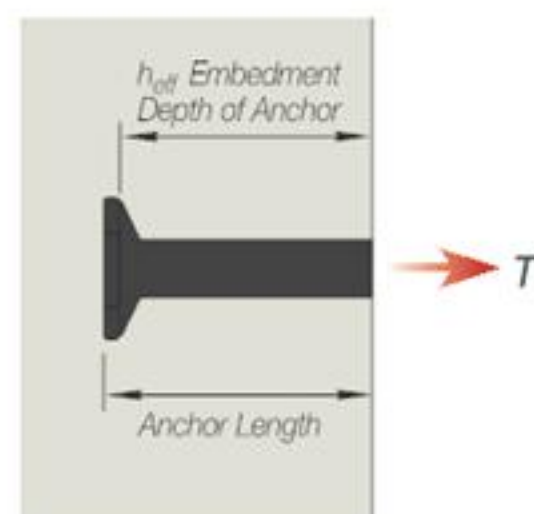

KSN Anchors with Timber Carrier
(Anchor Inset 33mm from Face of Concrete)

Anchor Ref.	Rebar Dia. (mm)	Anchor Length (mm)	Minimum Wall Thickness (mm)	Embedment Depth h_{eff} (mm)	Anchor - Direct Tensile Resistance Load N_{Rd} (kN) C32/40 Concrete at Various Horizontal Spacings						
					150	200	250	300	350	400	450
KSN12S	12	115	175	142	28.1	37.4	46.8	49.2	49.2	49.2	49.2
KSN12M	12	150	210	177	31.4	41.8	49.2	49.2	49.2	49.2	49.2
KSN16S	16	130	190	157	29.5	39.4	49.2	59.1	68.9	78.8	87.4
KSN16M	16	160	220	187	32.2	43.0	53.7	64.5	75.2	86.0	87.4
KSN16L	16	190	250	217	34.7	46.3	57.9	69.4	81.0	87.4	87.4
KSN20S	20	150	210	177	31.4	41.8	52.3	62.7	73.2	83.6	94.1
KSN20M	20	190	250	217	34.7	46.3	57.9	69.4	81.0	92.6	104.2
KSN20L	20	230	290	257	37.8	50.4	63.0	75.6	88.2	100.8	113.4

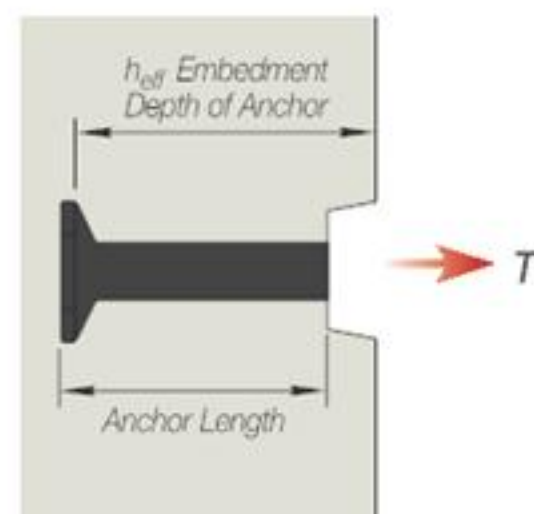

Design Example A. See page 9

Notes: All edges assumed to be at least $1.5 \times h_{eff}$ from anchor centreline.

Bold figures indicate performance equal or greater than reinforcement design resistance.

Double Line of Identical Anchors in Direct Tension Without Moment:

KSN Anchors Flush with Concrete

Anchor Ref.	Rebar Dia. (mm)	Anchor Length (mm)	Minimum Wall Thickness (mm)	Embedment Depth h_{eff} (mm)	Slab Depth (mm)	Anchor - Direct Tensile Resistance Load N_{Rd} (kN) C32/40 Concrete at Various Horizontal Spacings						
						150	200	250	300	350	400	450
KSN12S	12	115	175	109	200	10.4	13.9	17.3	20.8	24.2	27.7	31.2
					300	17.9	23.9	29.9	35.8	41.8	47.8	53.7
KSN12M	12	150	175	144	200	9.0	12.1	15.1	18.1	21.1	24.1	27.1
					300	15.6	20.8	26.0	31.2	36.4	41.6	46.8
KSN16S	16	130	175	124	200	9.5	12.6	15.8	18.9	22.1	25.2	28.4
					300	16.5	22.0	27.5	33.0	38.5	44.0	49.5
KSN16M	16	160	185	154	200	8.5	11.3	14.1	17.0	19.8	22.6	25.5
					300	14.8	19.8	24.7	29.6	34.6	39.5	44.4
KSN16L	16	190	215	184	200	7.8	10.4	12.9	15.5	18.1	20.7	23.3
					300	13.6	18.1	22.6	27.1	31.6	36.1	40.7
KSN20S	20	150	175	144	200	8.5	11.3	14.2	17.0	19.9	22.7	25.5
					300	15.1	20.1	25.1	30.1	35.1	40.2	45.2
KSN20M	20	190	215	184	200	7.5	10.0	12.5	15.1	17.6	20.1	22.6
					300	13.3	17.8	22.2	26.6	31.1	35.5	40.0
KSN20L	20	230	255	224	200	6.8	9.1	11.4	13.6	15.9	18.2	20.5
					300	12.1	16.1	20.1	24.1	28.2	32.2	36.2

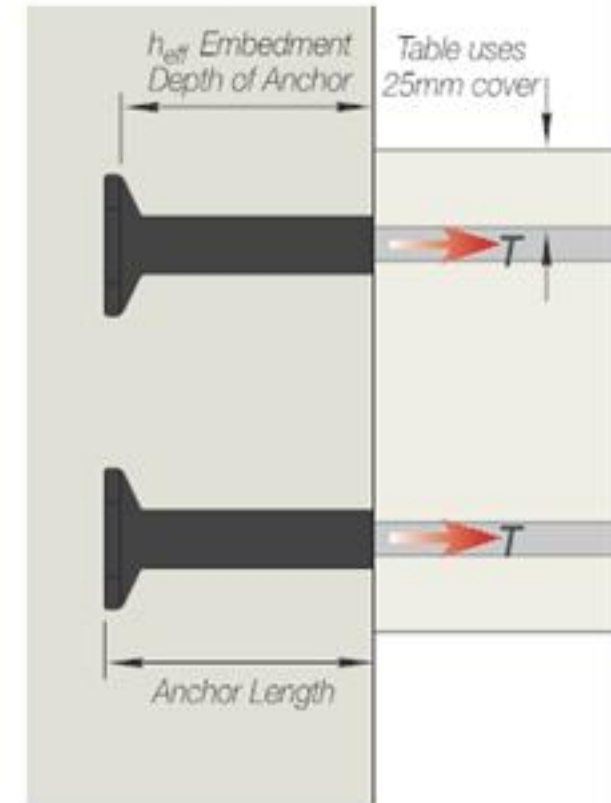

KSN Anchors with Timber Carrier (Anchor Inset 33mm from Face of Concrete)

Anchor Ref.	Rebar Dia. (mm)	Anchor Length (mm)	Minimum Wall Thickness (mm)	Embedment Depth h_{eff} (mm)	Slab Depth (mm)	Anchor - Direct Tensile Resistance Load N_{Rd} (kN) C32/40 Concrete at Various Horizontal Spacings						
						150	200	250	300	350	400	450
KSN12S	12	115	175	142	200	9.1	12.1	15.2	18.2	21.2	24.3	27.3
					300	15.7	20.9	26.2	31.4	36.6	41.9	47.1
KSN12M	12	150	210	177	200	8.2	10.9	13.6	16.3	19.0	21.7	24.5
					300	14.1	18.7	23.4	28.1	32.8	37.5	42.2
KSN16S	16	130	190	157	200	8.4	11.2	14.0	16.8	19.6	22.4	25.2
					300	14.7	19.6	24.4	29.4	34.2	39.1	44.0
KSN16M	16	160	220	187	200	7.7	10.3	12.8	15.4	18.0	20.5	23.1
					300	13.4	17.9	22.4	26.9	31.4	35.9	40.3
KSN16L	16	190	250	217	200	7.2	9.5	11.9	14.3	16.7	19.1	21.4
					300	12.5	16.6	20.8	25.0	29.1	33.2	37.4
KSN20S	20	150	210	177	200	7.7	10.2	12.8	15.4	17.9	20.5	23.0
					300	13.6	18.1	22.6	27.2	31.7	36.2	40.8
KSN20M	20	190	250	217	200	6.9	9.2	11.6	13.9	16.2	18.5	20.8
					300	12.3	16.4	20.5	24.5	28.6	32.7	36.8
KSN20L	20	230	290	257	200	6.4	8.5	10.6	12.7	14.9	17.0	19.1
					300	11.3	15.0	18.8	22.5	26.3	30.1	33.8

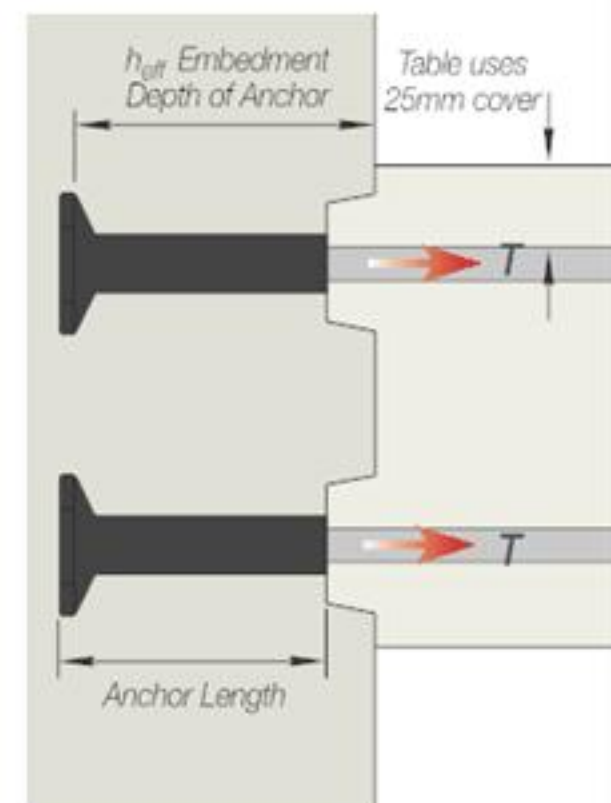

Notes: All edges assumed to be at least $1.5 \times h_{eff}$ from anchor centreline.
Bold figures indicate performance equal or greater than reinforcement design resistance.

Ancon KSN Anchors



Tensile concrete design resistance loads in wall-to-slab connections:

KSN Anchors with Timber Carrier (Anchor Inset 33mm from Face of Concrete)
 Moment Connection - Slab Top Main Steel Reinforcement 25mm Cover

Rebar Dia. (mm)	Anchor Length (mm)	Minimum Wall Thickness (mm)	Embedment Depth h_{eff} (mm)	Slab Depth (mm)	Anchor - Direct Tensile Design Resistance Load N_{Rd} (kN) C32/40 Concrete at Various Spacings						
					Horizontal Spacing (mm)						
KSN Anchor KSN12S					150	175	200	225	250	275	300
12	115	175	142	175	49.2	49.2	49.2	49.2	49.2	49.2	49.2
				200	49.2	49.2	49.2	49.2	49.2	49.2	49.2
				225	49.2	49.2	49.2	49.2	49.2	49.2	49.2
				250	49.2	49.2	49.2	49.2	49.2	49.2	49.2
				275	45.7	45.7	45.7	45.7	46.8	49.2	49.2
				300	39.2	39.2	39.2	42.1	46.8	49.2	49.2
KSN Anchor KSN12M											
12	150	210	177	175	49.2	49.2	49.2	49.2	49.2	49.2	49.2
				200	49.2	49.2	49.2	49.2	49.2	49.2	49.2
				225	49.2	49.2	49.2	49.2	49.2	49.2	49.2
				250	49.2	49.2	49.2	49.2	49.2	49.2	49.2
				275	49.2	49.2	49.2	49.2	49.2	49.2	49.2
				300	49.2	49.2	49.2	49.2	49.2	49.2	49.2

Notes: Refer to key design considerations on page 8. In addition, the tables assume no close edges and a cover to the top and bottom reinforcement connecting to the anchor of 25mm. For other cover, please contact Ancon. **Bold** figures indicate performance equal to or greater than reinforcement design resistance. If not bold, anchor resistance is limited by the concrete design resistance and Ancon recommends the use of secondary wall reinforcement (see page 17).

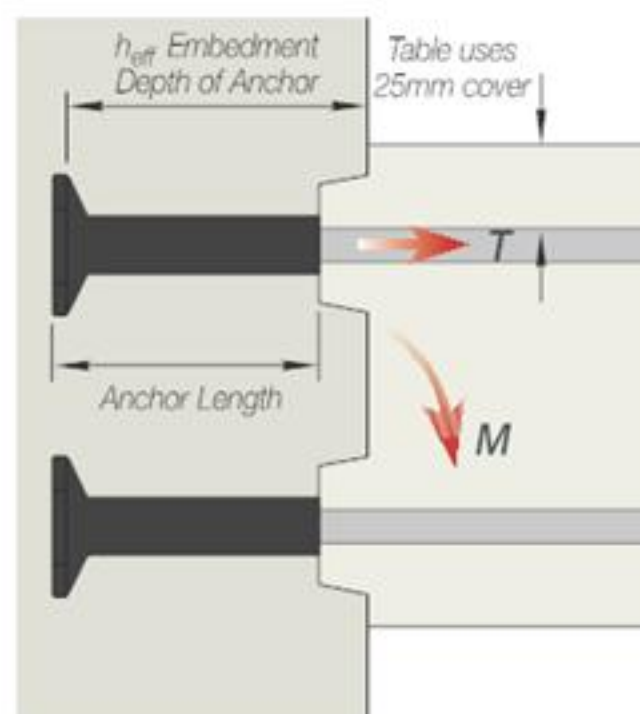

For bottom anchorage options, see pages 7 and 16.



KSN Anchors with Timber Carrier (Anchor Inset 33mm from Face of Concrete)
 Moment Connection - Slab Top Main Steel Reinforcement 25mm Cover

Rebar Dia. (mm)	Anchor Length (mm)	Minimum Wall Thickness (mm)	Embedment Depth h_{eff} (mm)	Slab Depth (mm)	Anchor - Direct Tensile Design Resistance Load N_{Rd} (kN) C32/40 Concrete at Various Spacings						
					Horizontal Spacing (mm)						
KSN Anchor KSN16S					150	175	200	225	250	275	300
16	130	190	157	175	73.8	86.1	87.4	87.4	87.4	87.4	87.4
				200	73.8	86.1	87.4	87.4	87.4	87.4	87.4
				225	73.8	85.9	85.9	85.9	85.9	85.9	85.9
				250	72.8	72.8	72.8	72.8	72.8	72.8	72.8
				275	62.4	62.4	62.4	62.4	62.4	62.4	62.4
				300	54.0	54.0	54.0	54.0	54.0	54.1	59.1
KSN Anchor KSN16M											
16	160	220	187	175	80.6	87.4	87.4	87.4	87.4	87.4	87.4
				200	80.6	87.4	87.4	87.4	87.4	87.4	87.4
				225	80.6	87.4	87.4	87.4	87.4	87.4	87.4
				250	80.6	87.4	87.4	87.4	87.4	87.4	87.4
				275	80.6	87.4	87.4	87.4	87.4	87.4	87.4
				300	80.6	87.4	87.4	87.4	87.4	87.4	87.4
KSN Anchor KSN16L											
16	190	250	217	175	86.8	87.4	87.4	87.4	87.4	87.4	87.4
				200	86.8	87.4	87.4	87.4	87.4	87.4	87.4
				225	86.8	87.4	87.4	87.4	87.4	87.4	87.4
				250	86.8	87.4	87.4	87.4	87.4	87.4	87.4
				275	86.8	87.4	87.4	87.4	87.4	87.4	87.4
				300	86.8	87.4	87.4	87.4	87.4	87.4	87.4

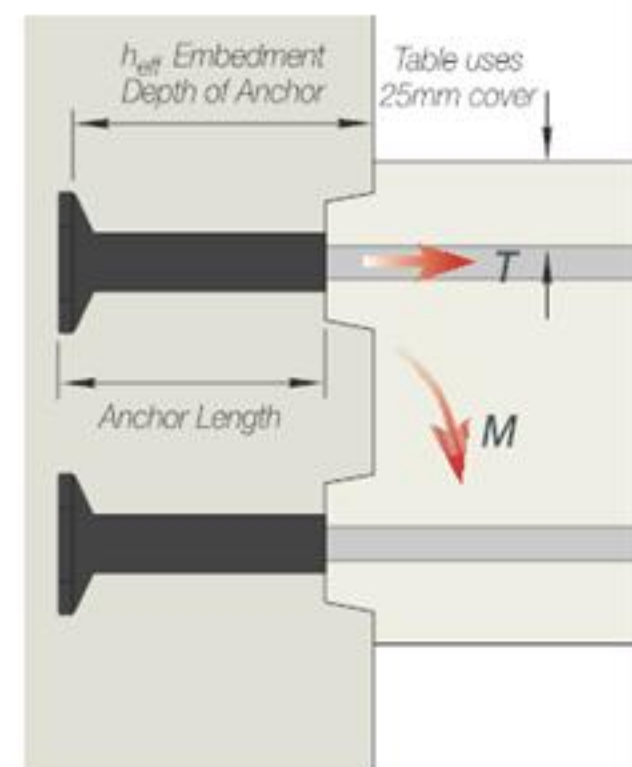

Notes: Refer to key design considerations on page 8. In addition, the tables assume no close edges and a cover to the top and bottom reinforcement connecting to the anchor of 25mm. For other cover, please contact Ancon. **Bold** figures indicate performance equal to or greater than reinforcement design resistance. If not bold, anchor resistance is limited by the concrete design resistance and Ancon recommends the use of secondary wall reinforcement (see page 17).

Design Example B. See page 9

For bottom anchorage options, see pages 7 and 16.

Ancon KSN Anchors

KSN Anchors with Timber Carrier (Anchor Inset 33mm from Face of Concrete)
 Moment Connection - Slab Top Main Steel Reinforcement 25mm Cover

Rebar Dia. (mm)	Anchor Length (mm)	Minimum Wall Thickness (mm)	Embedment Depth h_{eff} (mm)	Slab Depth (mm)	Anchor - Direct Tensile Design Resistance Load N_{Rd} (kN) C32/40 Concrete at Various Spacings						
					Horizontal Spacing (mm)						
KSN Anchor KSN20S					150	175	200	225	250	275	300
20	150	210	177	175	78.4	91.5	104.5	117.6	130.7	136.6	136.6
				200	78.4	91.5	104.5	117.6	130.7	136.6	136.6
				225	78.4	91.5	104.5	117.6	121.8	121.8	121.8
				250	78.4	91.5	103.8	103.8	103.8	103.8	103.8
				275	78.4	89.5	89.5	89.5	89.5	89.5	89.5
				300	77.9	77.9	77.9	77.9	77.9	77.9	77.9
KSN Anchor KSN20M											
20	190	250	217	175	86.8	101.3	115.7	130.2	136.6	136.6	136.6
				200	86.8	101.3	115.7	130.2	136.6	136.6	136.6
				225	86.8	101.3	115.7	130.2	136.6	136.6	136.6
				250	86.8	101.3	115.7	130.2	136.6	136.6	136.6
				275	86.8	101.3	115.7	130.2	136.6	136.6	136.6
				300	86.8	101.3	115.7	130.2	136.6	136.6	136.6
KSN Anchor KSN20L											
20	230	290	257	175	94.5	110.2	126.0	136.6	136.6	136.6	136.6
				200	94.5	110.2	126.0	136.6	136.6	136.6	136.6
				225	94.5	110.2	126.0	136.6	136.6	136.6	136.6
				250	94.5	110.2	126.0	136.6	136.6	136.6	136.6
				275	94.5	110.2	126.0	136.6	136.6	136.6	136.6
				300	94.5	110.2	126.0	136.6	136.6	136.6	136.6

Notes: Refer to key design considerations on page 8. In addition, the tables assume no close edges and a cover to the top and bottom reinforcement connecting to the anchor of 25mm. For other cover, please contact Ancon. **Bold** figures indicate performance equal to or greater than reinforcement design resistance. If not bold, anchor resistance is limited by the concrete design resistance and Ancon recommends the use of secondary wall reinforcement (see page 17).

Design Example C. See page 9

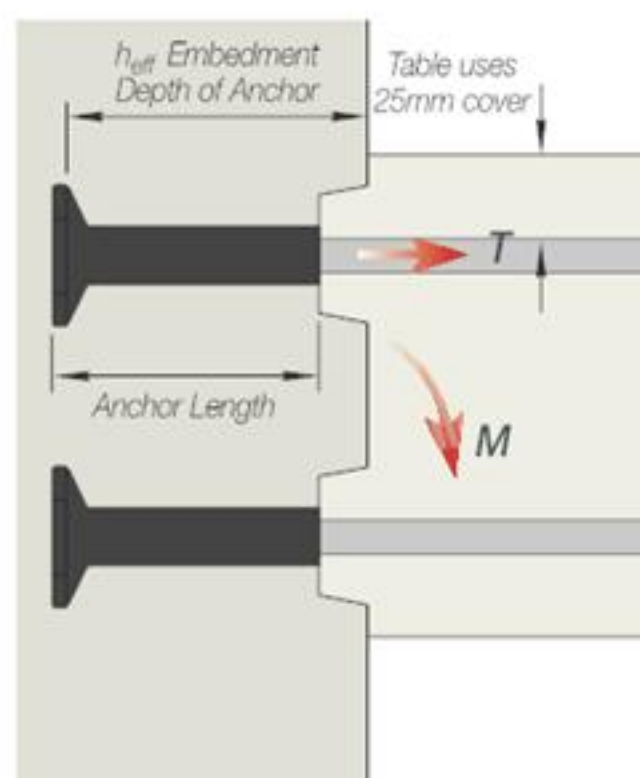

Reinforcement Details

Correct detailing of reinforcement in accordance with appropriate design codes and the recommendations provided here will ensure Ancon KSN Anchors attain the designed performance.

Top and Bottom Slab Anchor Connection

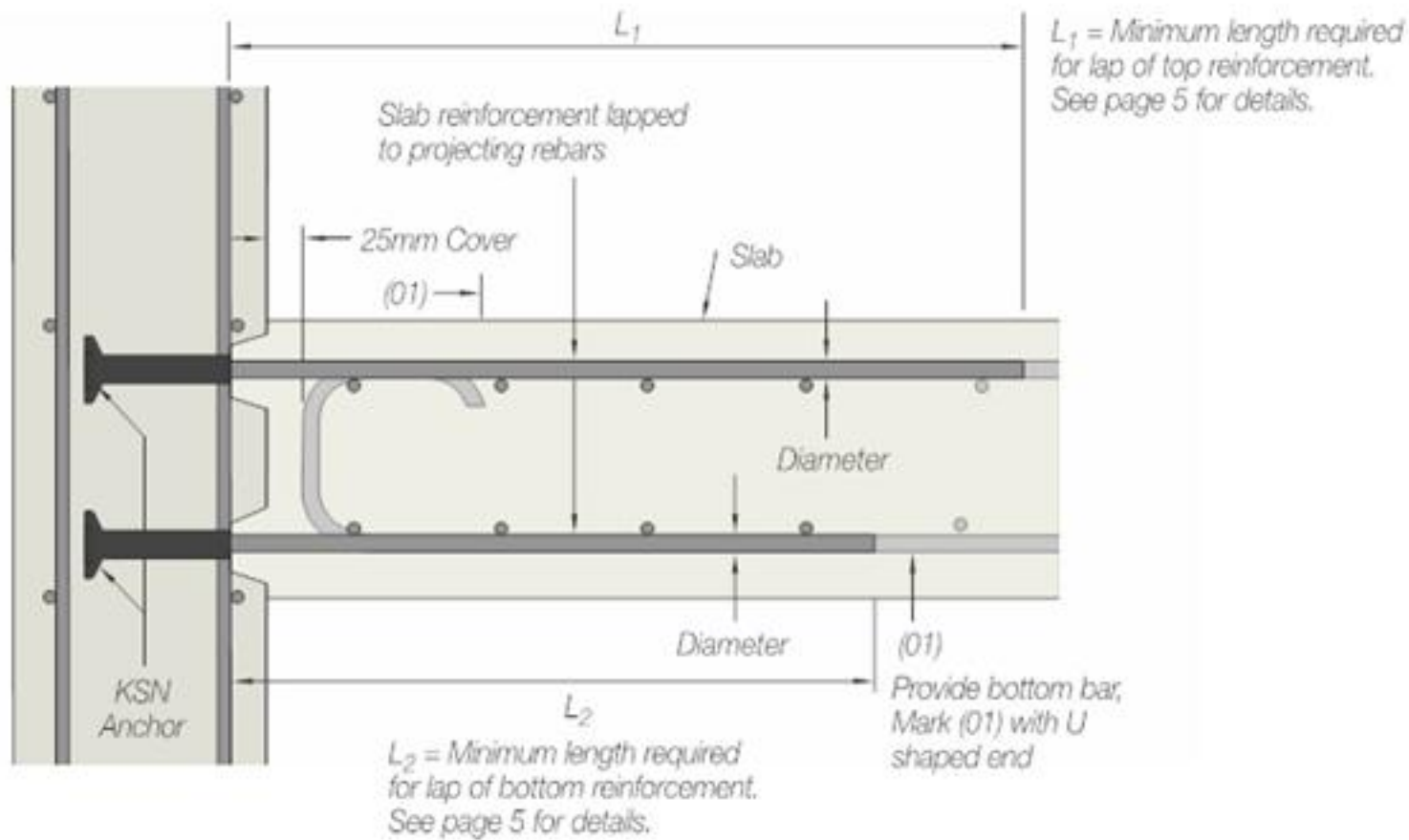

Wall Edge Reinforcement Details

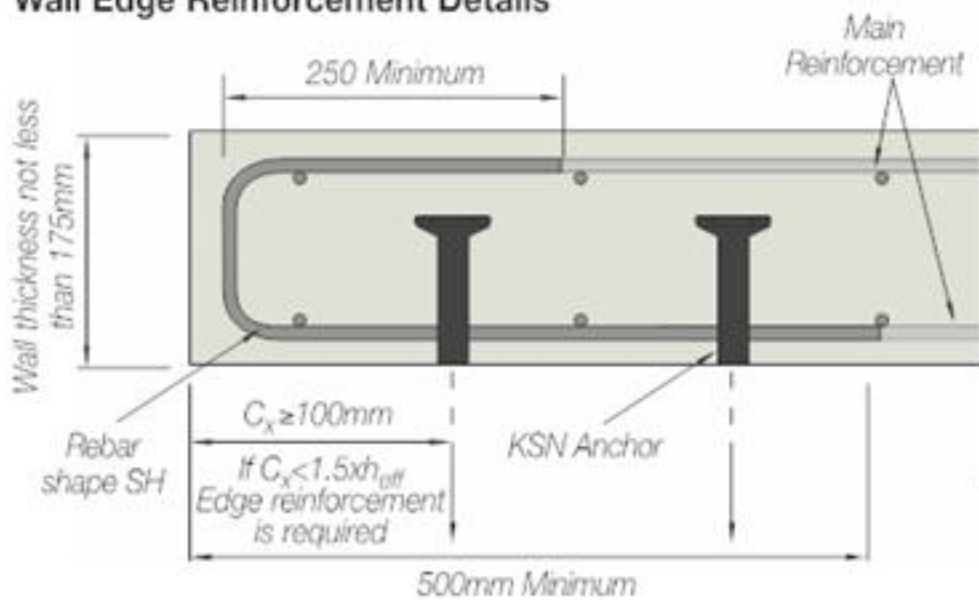

Reinforcement: Minimum edge reinforcement, 12mm diameter Grade B500B
The main reinforcement can be detailed to incorporate the above shape noted as rebar SH

Wall-Part Edge Section

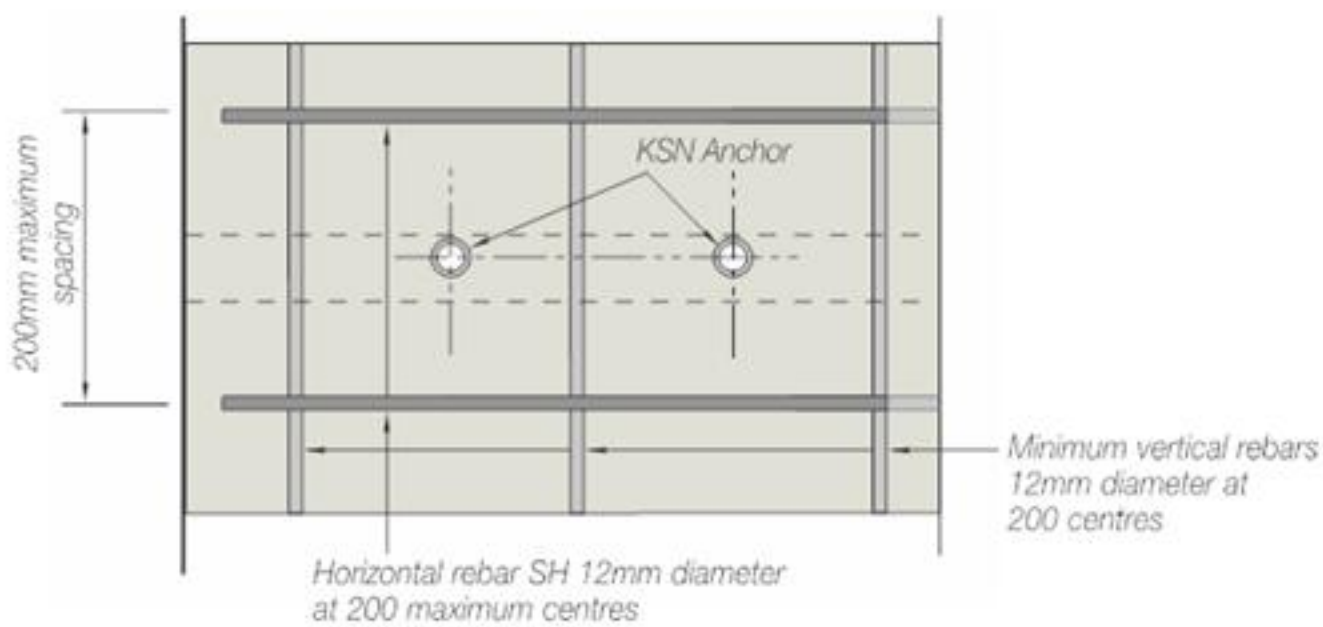

Wall-Part Edge Elevation



Ancon KSN Anchors

Bottom Anchor Design Guidance

In the moment connection configuration, the tension at the joint is resisted by the top anchor and the compression by the concrete. However, part of the span bottom reinforcement needs to be anchored in the wall according to BS EN 1992:1-1 (Eurocode 2) Clause 9.3.1.2. This anchorage of bottom reinforcement may be provided using KSN Anchors, an Ancon Eazistrip reinforcement continuity system or an Ancon Coupler Box.

The minimum bottom anchors recommended, based on the Ancon test programme, are KSN12S at the same spacing as the top anchors. The Engineer shall check that the tension capacity provided satisfies BS EN 1992:1-1 Clause 9.3.1.2 and upgrade the anchor size if necessary using the tension only table of this brochure (page 10) to check anchorage provided.

Example of bottom anchor design

Assumptions:

- Top anchors @ 200mm/c,
- Slab is 200mm thick with 25mm cover top and bottom,
- Simply supported slab designed for nominal moment at the joint,
- Span reinforcement 16mm diameter @ 200mm/c = 1005mm²/m
- Moment at support is 60kN.m and slab design gives $z = 156\text{mm}$,
- Shear is $V_{Ed} = 30\text{kN/m}$

From EC2 clause 9.3.1.2, minimum area of reinforcement to be anchored at support is 50% of span reinforcement, anchorage tension load to be provided by $F = V_{Ed} d/z$ according to clause 9.2.1.4.

Assume KSN12S bottom anchors at same spacing as top anchors = 200mm:

- Area provided is $565\text{mm}^2 > 1005/2 = 503\text{mm}^2$
- Bottom reinforcement anchorage tension required is $F = V_{Ed} d/z = 30 \times 169 / 156 = 32.5\text{kN}$
- Tension resistance provided by KSN12S anchors @ 200mm/c = 37.4kN from tension table (page 10).
KSN12S anchors at 200mm/c are satisfactory for bottom reinforcement anchorage.

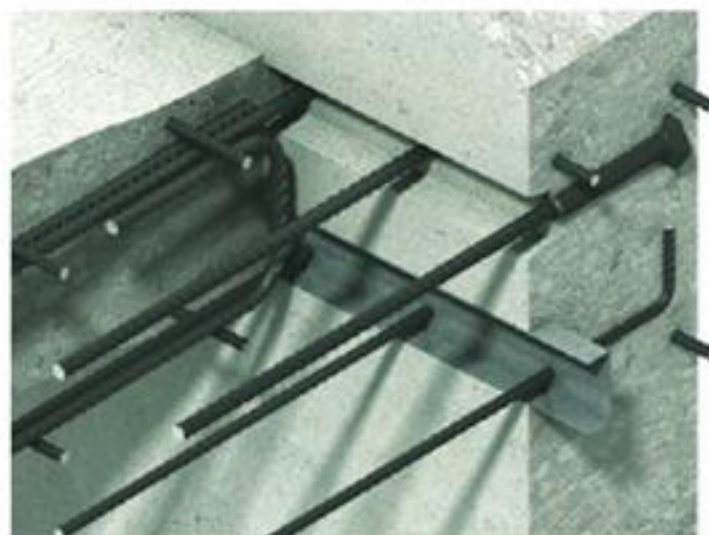

KSN Anchor System being used with an Eazistrip System

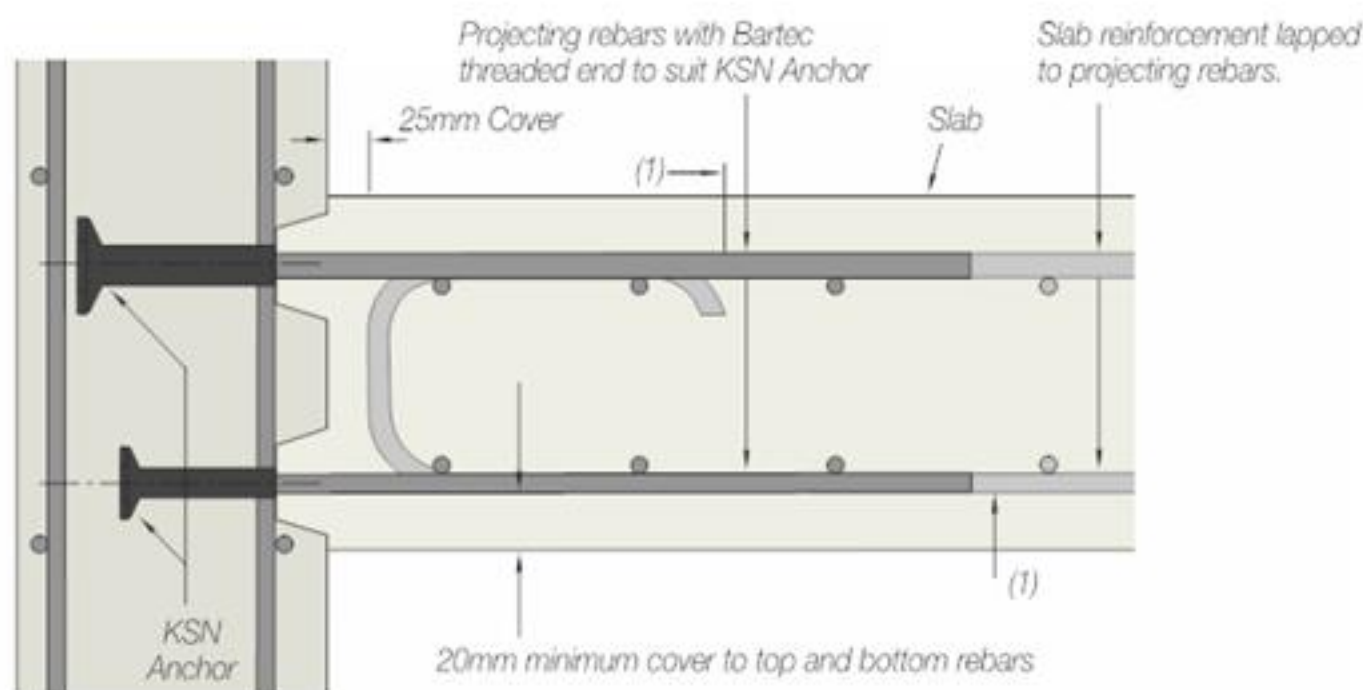

Wall / Slab Section - KSN Anchors at top and bottom

Other bottom anchorage options are an Eazistrip system and an Ancon Coupler Box.

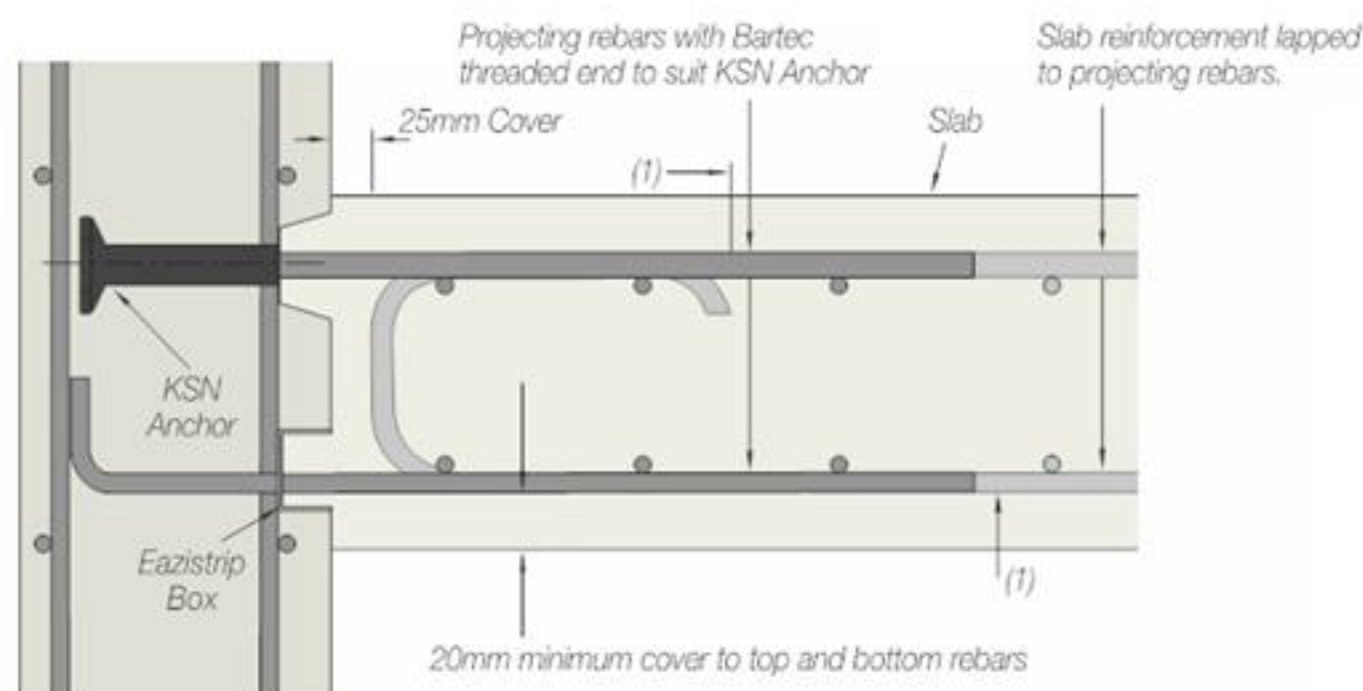

Wall / Slab Section - KSN Anchor at Top / Eazistrip System on bottom

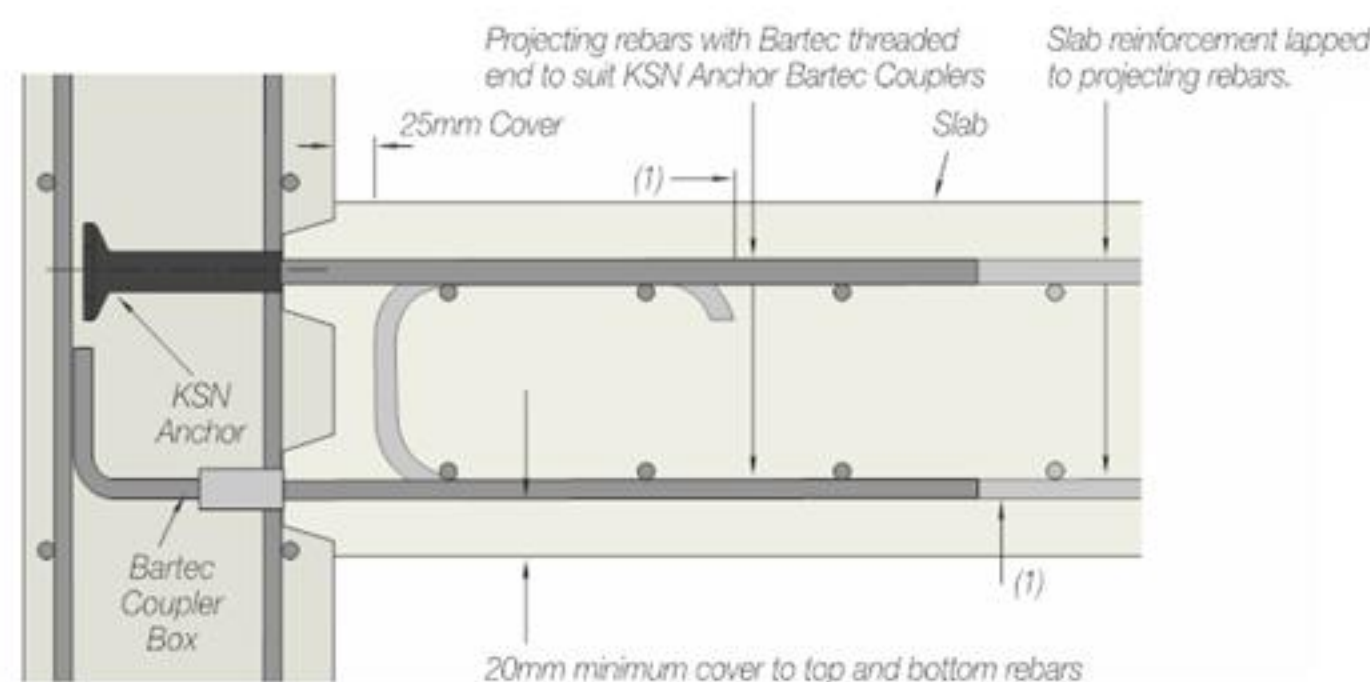

Wall / Slab Section - KSN Anchor at Top / Coupler Box on bottom

Guidance Regarding Ductility Requirement

The design of slab-wall connections should not be made in isolation but should be as part of a structural system. Ductility requirements of such a connection will depend on the robustness requirements of the structure of which it is part and the strategy chosen to achieve global robustness.

In the UK, the Building Regulations for England and Wales, for Scotland and for Northern Ireland all require buildings to be designed so that in the event of an accident the structure will not suffer collapse to an extent disproportionate to the cause.

Similarly, BS EN 1990 and BS EN 1991-1-7 (Eurocode 0 clause 2.1 and Eurocode 1 Part 1-7 clause 3) describe the necessity for the design to take into account accidental situations whether identified (clause 3.2) or unspecified (clause 3.3), and to mitigate the associated risk. Several possible strategies are proposed; one of them is the provision of sufficient robustness for the structure by

ensuring that structural members and materials have sufficient ductility, and are capable of absorbing significant strain energy without rupture [3.2 (3)]. If such ductility at the slab-wall connection is required to participate in the global robustness of the structure, one approach to comply with this requirement is the provision of additional wall reinforcement to prevent non-ductile failure of the anchor under accidental load.

This secondary reinforcement can be in the form of transverse links to be placed above and below the anchor in tension.

Proposed details are shown here.

Anchor Ref.	Bar Diameter (mm)	Anchor Length (mm)	Wall Thickness Above Which Secondary Wall Reinforcement Required* (mm)	Secondary Wall Reinforcement Requirement. 2 Links per Anchor. Link Diameter (mm)	Maximum Dimension A (mm)	Maximum Dimension B (mm)
KSN12S	12	115	185	8	120	50
KSN12M	12	150	220	8	120	50
KSN16S	16	130	200	8	120	55
KSN16M	16	160	230	8	120	55
KSN16L	16	190	260	8	120	55
KSN20S	20	150	220	10	135	60
KSN20M	20	190	260	10	135	60
KSN20L	20	230	300	10	135	60

*Where the standard 33mm timber anchor carrier is used.

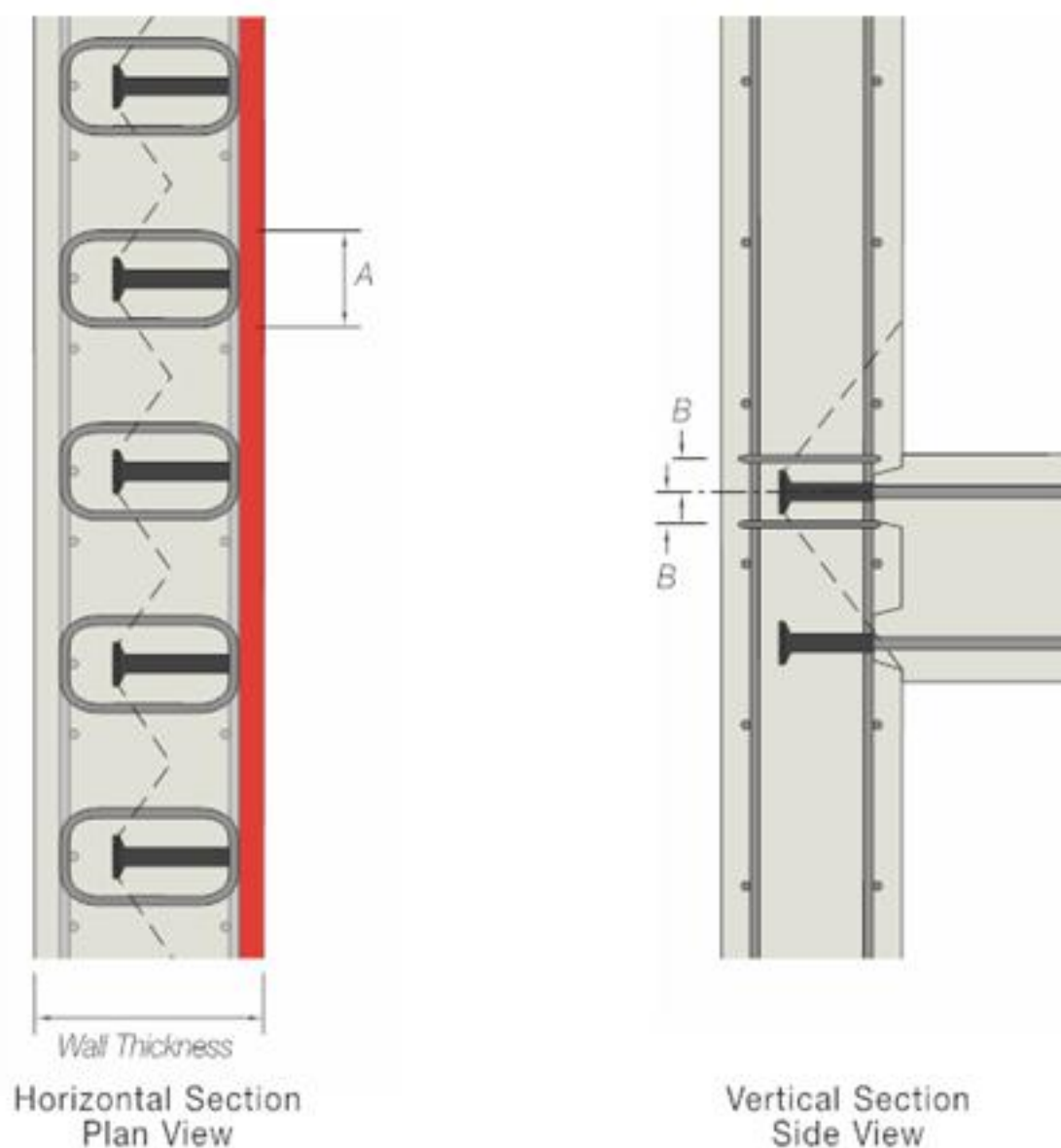

Ancon KSN Anchors

KSN Corner Guidance

KSN Anchors may be used to connect slabs to walls at corners as long as certain conditions are met.

Inside Corner

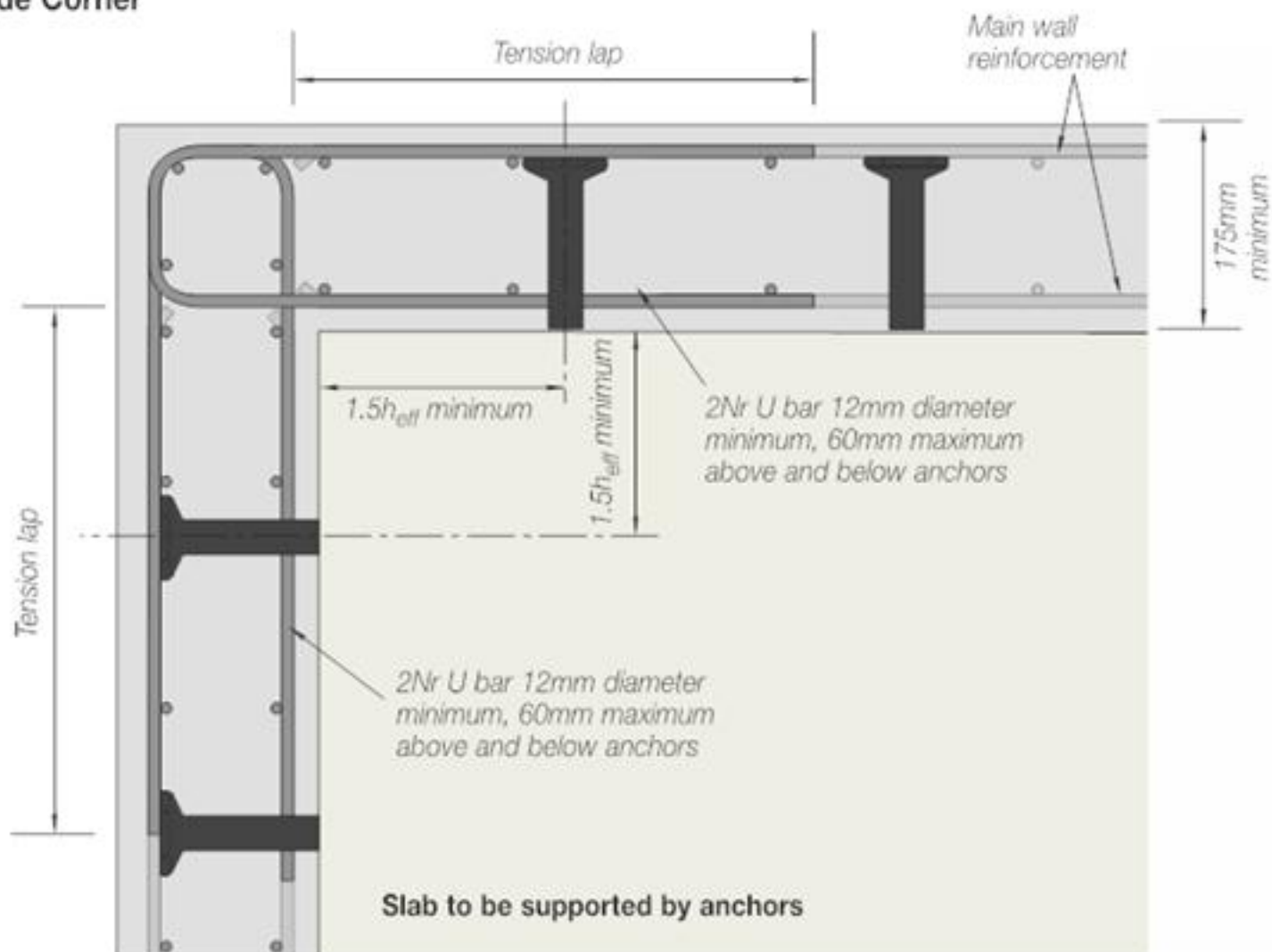

Recommendations:

- Additional U-shaped rebars are to be provided above and below the corner anchors
- Careful attention to detailing of the anchors at corner locations is required to avoid the possibility of a clash of the continuity bars

Re-entrant Corner

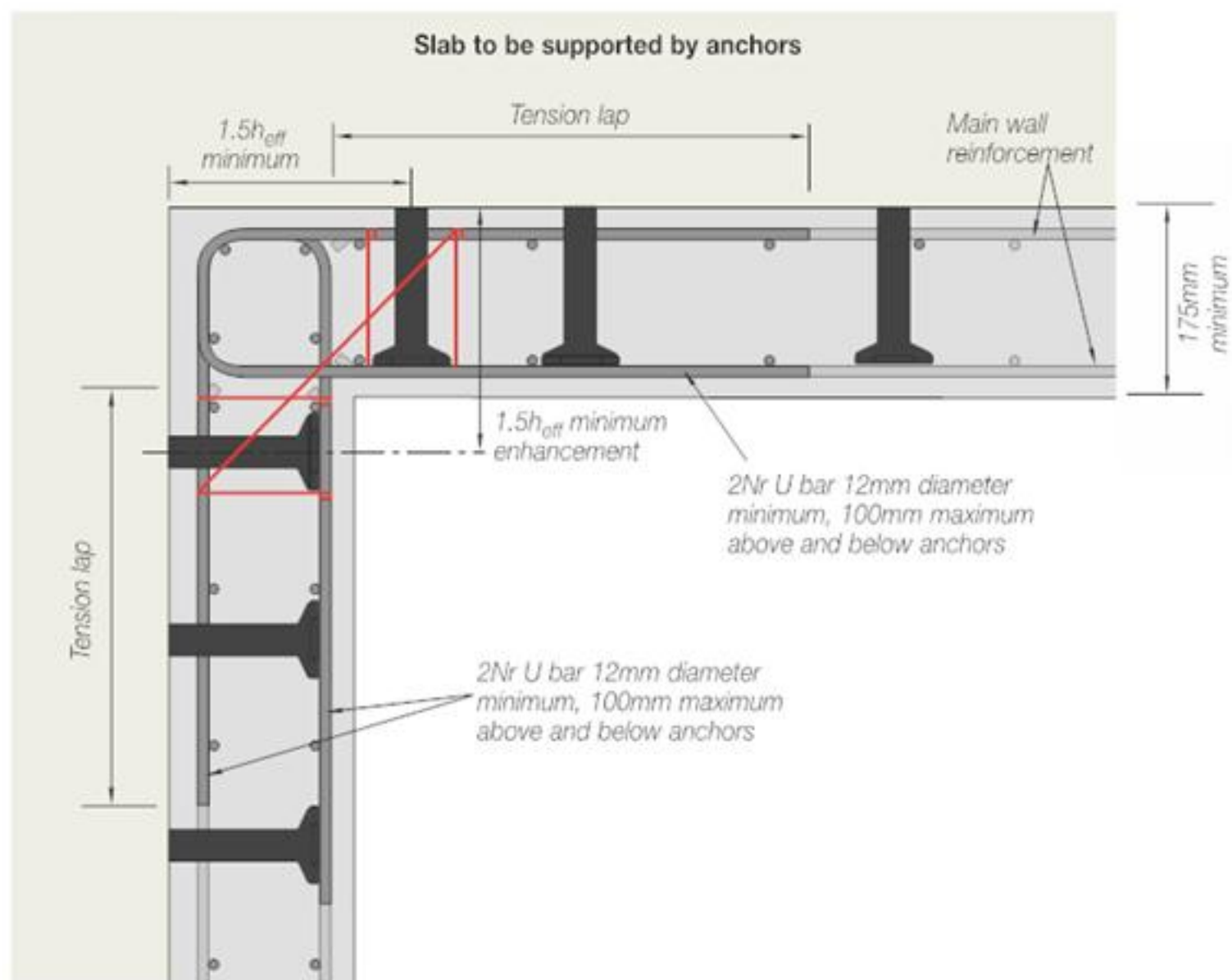

Recommendations:

- Additional U-shaped rebars are to be provided above and below the corner anchors
- For high moments a special detail may be required, for example links and diagonal bars (shown red), as recommended in BS EN 1992-1-1 Annex J and UK national annex
- Anchors at the re-entrant corner will have to resist higher loads than the current anchors due to the larger area of slab supported and therefore need to be designed for the specific loads applied to them

Guidance on Shear Checks

The shear capacity of the joint (vertical shear at the interface and horizontal shear in the wall) must be checked by the designer. The anchor carrier is creating a shear key for the wall-to-slab connection that complies with figure 6.9 of BS EN 1992:1-1 (Eurocode 2) for indented construction joint. Tests undertaken with top and bottom anchors have shown no sign of distress due to shear at the interface, however suitability must be checked by the designer. The effective wall depth to be used in the calculation of the horizontal shear resistance is limited to 175mm or the anchor embedment, whichever is the greater.

The following shear checks at the joint need to be undertaken:

- The shear on the vertical interface between the end of the slab and the face of the wall (1):
See Table below for indicative capacity of the shear keys for one or two lines of KSN Anchors using Ancon standard timber carrier. For higher shear load or different carrier please contact Ancon.

Shear key capacity according to EC2 of two lines of anchors on the vertical interface between the end of the slab and the face of the wall in kN/m for different concrete grades based on 69mm x 33mm timber carrier

Concrete Grade				
C32/40	C35/45	C40/50	C45/55	C50/60
96.6	101.2	115.0	124.2	133.4

Shear key capacity according to EC2 of one line of anchors on the vertical interface between the end of the slab and the face of the wall in kN/m for different concrete grades based on 69mm x 33mm timber carrier

Concrete Grade				
C32/40	C35/45	C40/50	C45/55	C50/60
48.3	50.6	57.5	52.1	66.7

- The horizontal shear in the wall within the depth of the slab. The horizontal shear in the wall shall be checked by the Engineer using EN 1992-1-1 clause 6.2.2 Members not requiring design shear reinforcement of EC2 taking into account the reduction factor $\beta = a_v / (2d)$ indicated in 6.2.2 (6). The applied joint shear $V_{Ed,j}$ should be calculated by taking into account any other shear forces applied to the wall; it will depend on the wall height.

The wall shear resistance $V_{Rd,c}$ depends on the wall reinforcement and is defined by:

$$V_{Rd,c} = [C_{Rd,c} k (100 \rho_1 f_{ck})^{1/3} + k_1 \sigma_{cp}] b_w d_w / \beta \quad (6.2.a)$$

$$\text{with a minimum of } V_{Rd,c,min} = [v_{min} + k_1 \sigma_{cp}] b_w d_w / \beta \quad (6.2.b)$$

$$\text{and a maximum of } V_{Rd,c,max} = 0.5 b_w d_w v f_{cd}$$

with $C_{Rd,c} = 0.18/\gamma_c = 0.12$ from UK National Annex

$$k = 1 + (200/d_w)^{0.5} \leq 2.0 \text{ with } d_w \text{ in mm}$$

$$\rho_1 = A_{s1}/(b_w d_w) \leq 0.02 \text{ ratio of wall vertical reinforcement on the face of the wall near the slab.}$$

f_{ck} is the characteristic compressive cylinder strength of concrete at 28 days

$$k_1 = 0.15 \text{ from UK National Annex}$$

$\sigma_{cp} = N_{Ed}/A_c < 0.2f_{cd}$ with N_{Ed} compression force applied to the cross section and A_c the area of concrete of the cross section.

b_w is the wall width resisting the shear load and $d_w = \max(h_{eff}, 175\text{mm})$, wall effective depth

$\beta = \alpha_{vj} / (2d_w)$ with α_{vj} the shear span of the joint equal to the distance between the slab neutral surface and the edge of the anchor head

p_h is the projection of anchor head (see adjacent table for details)

$$v_{min} = 0.035 k^{3/2} f_{ck}^{0.5} \text{ from UK National Annex}$$

$$v = 0.6 [1 - f_{ck}/250]$$

f_{cd} is the design value of the concrete compressive strength

x is the distance between the slab soffit and the Neutral surface of the slab

s is the depth of the concrete stress block

Contact Ancon for a step by step design example.

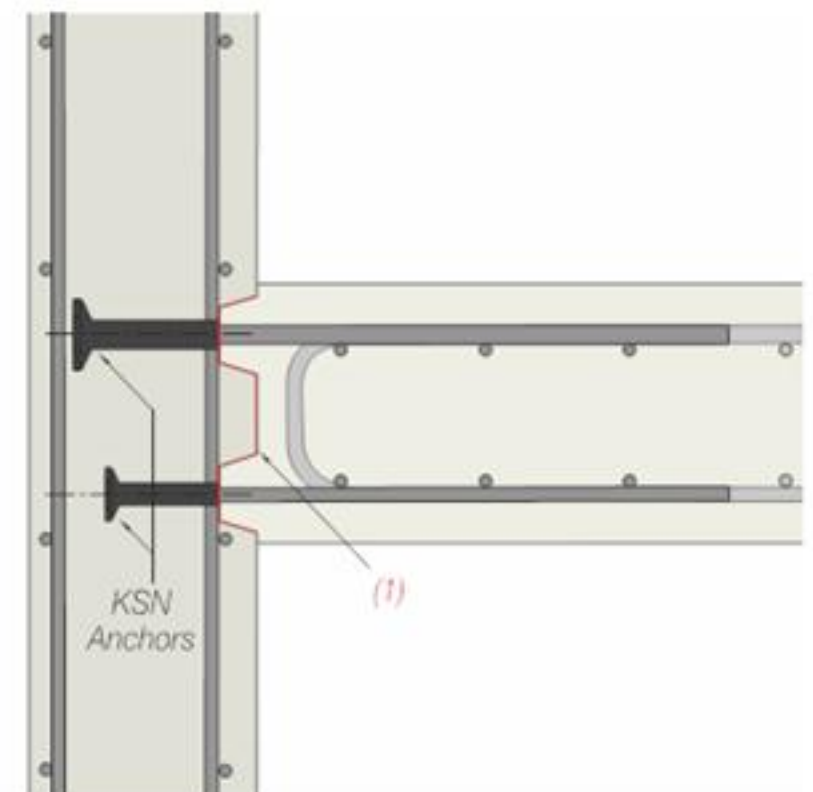

Wall/Slab Section - KSN Anchors

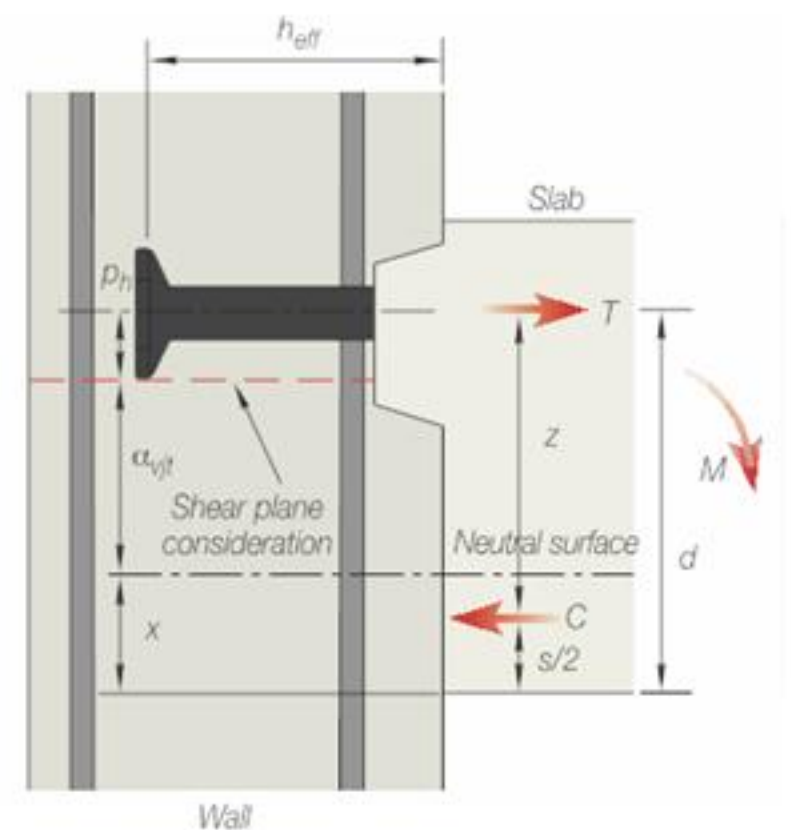

Shear plane considered at the edge of the anchor head

Anchor Type	Projection of Anchor Head p_h (mm)
KSN12S, KSN12M	20.0
KSN16S, KSN16M, KSN16L	26.5
KSN20S, KSN20M, KSN20L	32.5

Ancon KSN Anchors

Installation Guidance

Reinforcement continuity systems contribute to the stability of a structure and therefore it is essential that the correct installation procedures are followed. Brief installation guidance is given here. A more detailed installation guide is issued to site with the system.

Prior to Installation

Before installation, any loose anchors should be tightened to the timber carrier to ensure that the anchors will not move during concreting. Normal handling precautions to avoid physical injury apply and personal protection equipment should be worn.

The tape on the face of the timber strip should not be removed as it will prevent concrete ingress in the hex socket.

A formwork release agent should be applied to the timber strip and any spillage must be removed from the anchors.

The omission of the release agent will prevent the easy removal of the timber strip at a later stage and if the timber strip cannot be completely removed, the capacity of the joint may be compromised.



The timber carrier supporting the anchors is positioned against the formwork at the required location of the adjoining slab, orientated to the instructions on the label which indicates that the coloured side should face up. The timber is fixed to the formwork with nails. It is important that the strip is set to the correct position within tolerance, is the right way up and fixed to prevent any movement during concreting.



The KSN anchors are to be used only with Bartec continuation bars provided by Ancon.

The Bartec continuation bar thread should be checked to be free of any dirt and be positioned at the anchor location and rotated to fit into the anchor thread. The connection should then be tightened by using a hand wrench. No torqueing is required.

After tightening there should be no more than 2-4mm of thread exposed, depending on the diameter of the rebar.

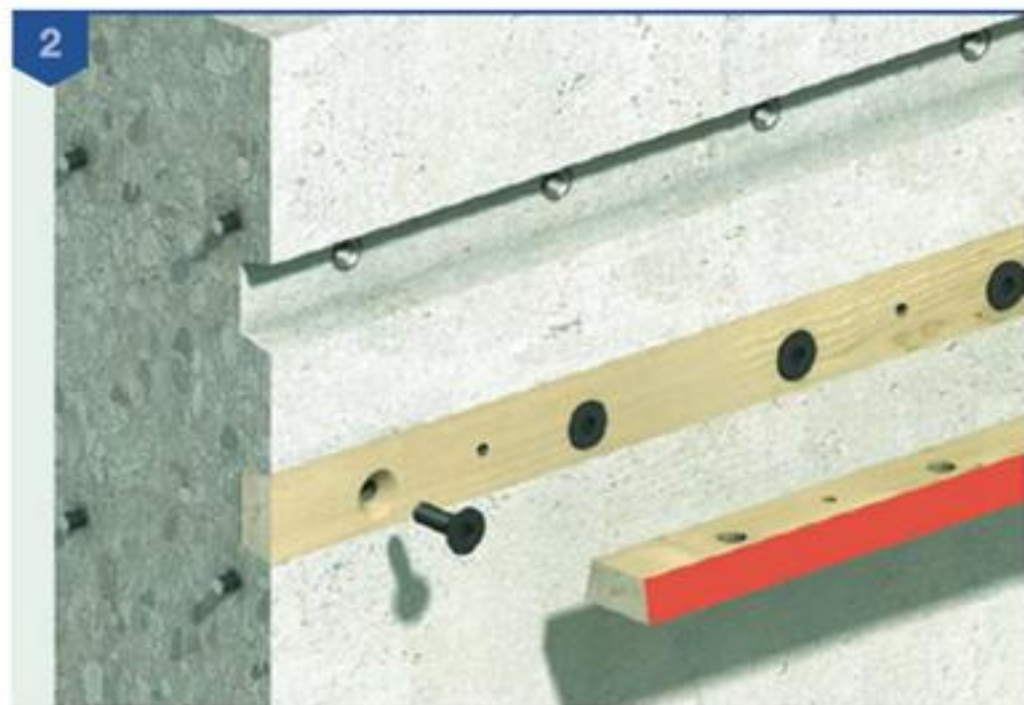

Other wall reinforcement should be installed to the Engineer's details, based on Ancon's recommendations. The concrete is then cast and once it has reached sufficient strength, the formwork is removed to reveal the face of the timber strip with the protective tape.

When installation of the continuation bars is required, the tape is removed to reveal the socket head cap screws which can be unscrewed using the corresponding Allen key (supplied with each order). Three M10 tee nuts have been inserted in each timber strip in order to allow for the use of M10 studs/bolts to help push the first timber strip out.



Slab reinforcement should be installed to the Engineers details. The slab is cast to complete the application.

Installation Tolerances

In order to ensure adequate cover to the continuation bar and to comply with the design, it is important that the timber anchor carrier is set to the correct position, the right way up and fixed to prevent any movement during concreting. The carrier's installation tolerances are shown below and these tolerances are not cumulative.



Timber Anchor Carrier Setting Out Deviation Allowances

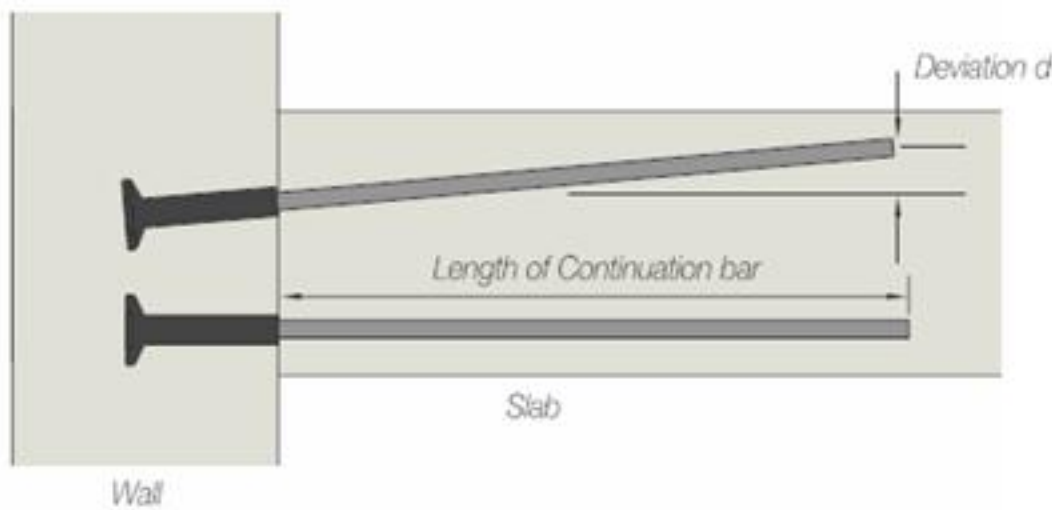

Vertical Transverse Section Alignment of Anchor Side View

Length of Continuation Bar (mm)	Deviation d
700	+/- 2mm
1000	+/- 3mm
1500	+/- 5mm

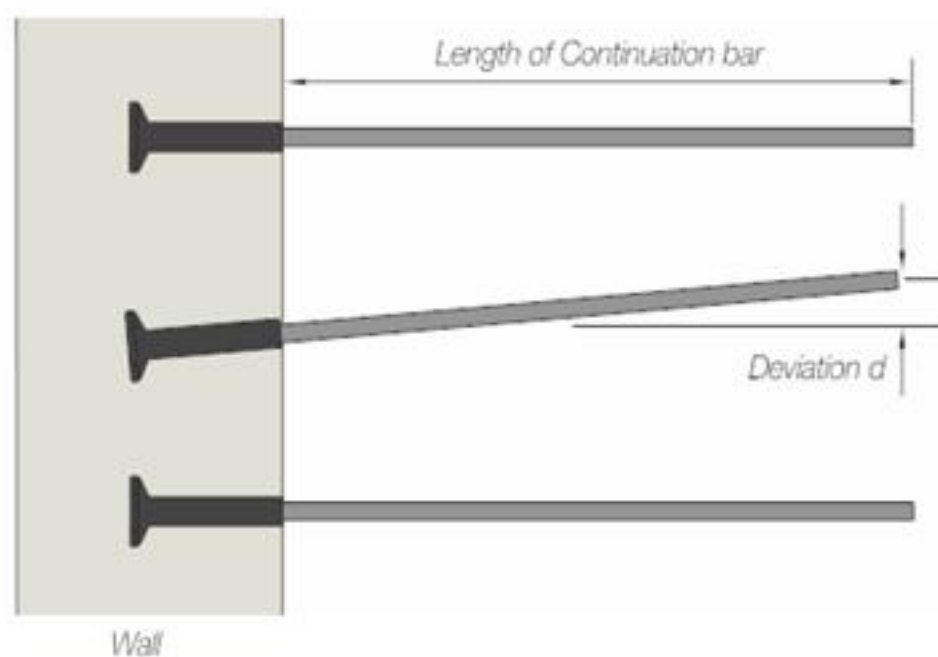

Horizontal Transverse Section Alignment of Anchor Plan View

Length of Continuation Bar (mm)	Deviation d
700	+/- 10mm
1000	+/- 12mm
1500	+/- 20mm

Tools required for installation:
 KSN 12 - 10mm A/F Allen Key / Hex Head Wrench
 KSN 16 - 12mm A/F Allen Key / Hex Head Wrench
 KSN 20 - 14mm A/F Allen Key / Hex Head Wrench
 M10 Stud/bolt to push timber away from concrete
 Hand Wrench to suit continuation bar diameter

Other requirement:
 Formwork release agent

Ancon KSN Anchors

Guidance for cutting standard length anchor carrier

In some instances, at the end of a run of anchors for example, a non-standard carrier length may be required. In order to achieve this, the standard timber carrier may be cut to suit, under the following conditions:

- Anchor carriers are to be installed end to end without any gaps between them at all locations
- The specified spacing between anchors must never be exceeded
- The actual anchor spacing can be reduced to below the specified spacing but with a minimum of 150mm
- Minimum edge distance should be 100mm

Cut at the end of a run

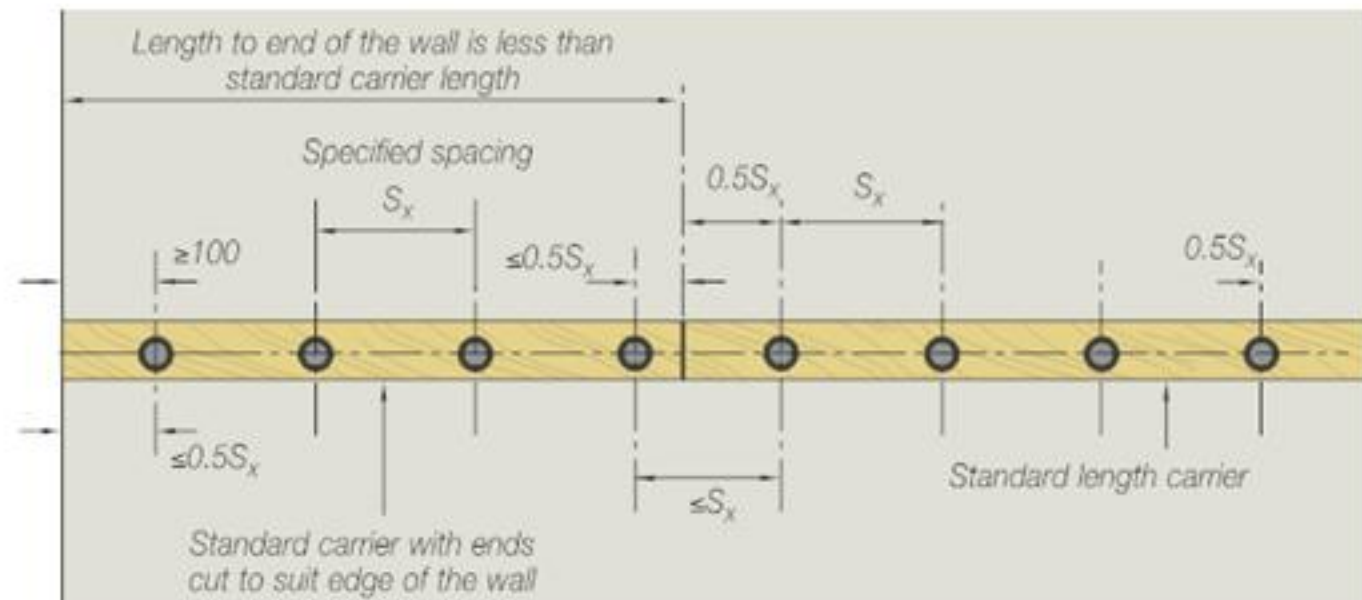

Wall Elevation



Plan View

Cut in the middle of a run

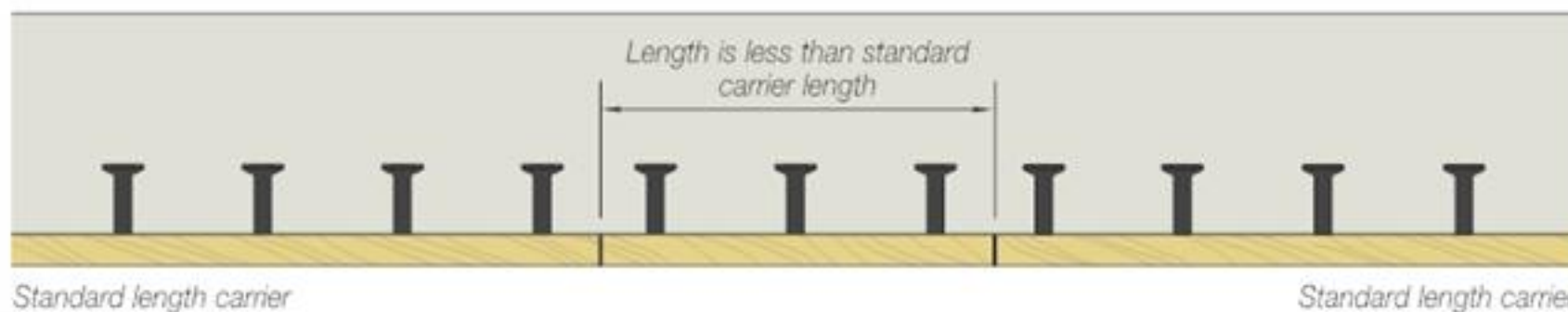

Plan View

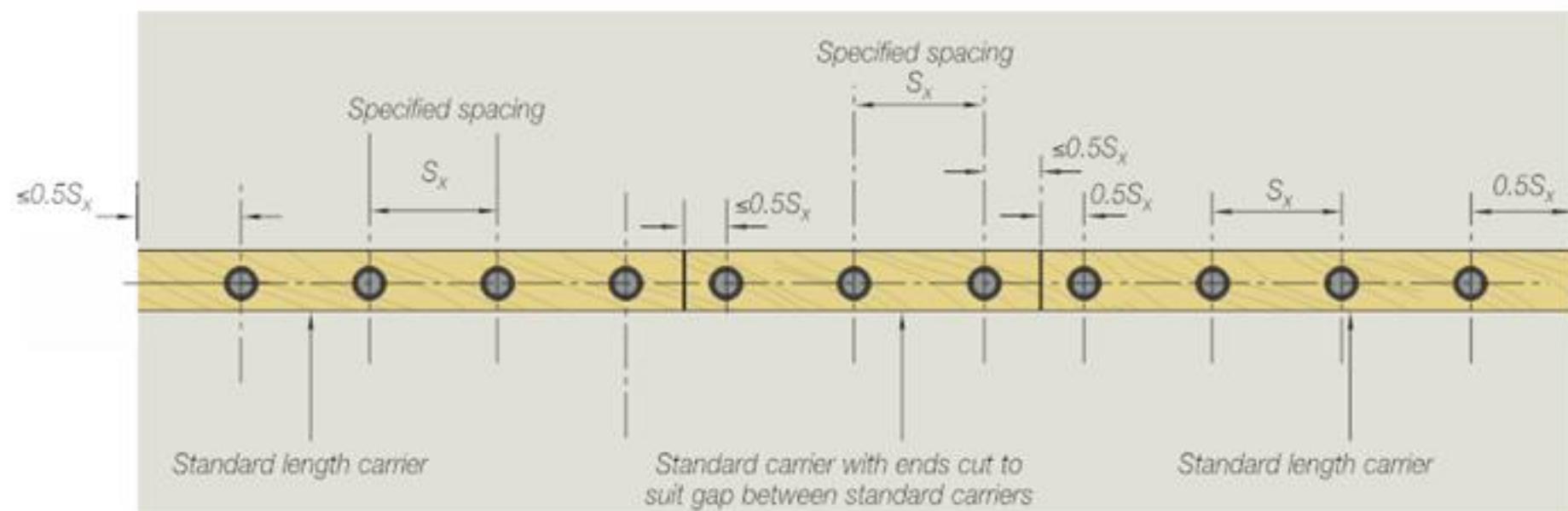

Wall Elevation

Project References

Australia

Although new to Europe, Ancon KSN Anchors have been used extensively by the Australian concrete industry for many years. Project references include the two high rise developments featured here.



Soul Apartments, Brisbane



The Oracle Towers, Brisbane

Other Ancon Products

Reinforcing Bar Couplers

The use of reinforcing bar couplers can provide significant advantages over lapped joints. Design and construction of the concrete can be simplified and the amount of reinforcement required can be reduced. The Ancon range includes Bartec parallel threaded, TT tapered threaded and MBT mechanically bolted couplers.



Reinforcement Continuity Systems

Reinforcement Continuity Systems are an increasingly popular means of maintaining continuity of reinforcement at construction joints in concrete. Ancon Eazistrip is approved by UK Cares and consists of pre-bent bars housed within a galvanised steel casing. Once installed, the protective cover is removed and the bars are straightened.



Shear Load Connectors

Ancon DSD and ESD Shear Load Connectors are used to transfer shear across expansion and contraction joints in concrete. They are more effective at transferring load and allowing movement to take place than standard dowels, and can be used to eliminate double columns at structural movement joints in buildings. A Lockable Dowel is available for temporary movement joints in post-tensioned concrete.

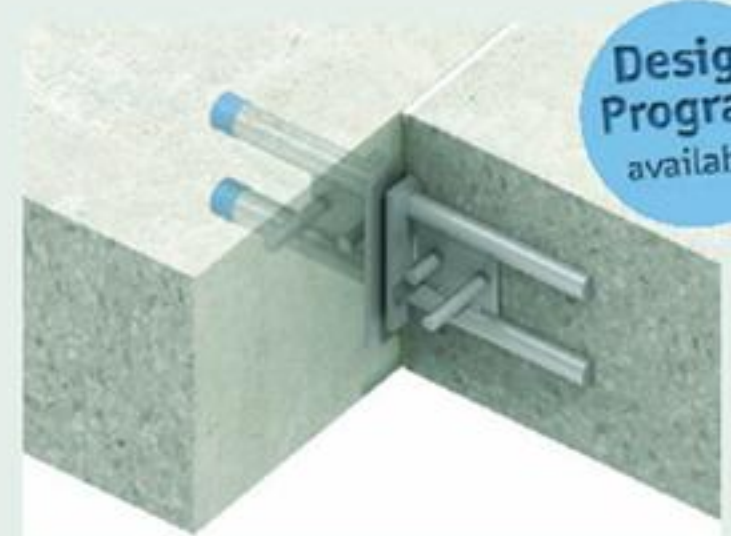

Punching Shear Reinforcement

Used within a slab to provide additional reinforcement around columns, Ancon Shearfix is the ideal solution to the design and construction problems associated with punching shear. This CARES-approved system consists of double-headed studs welded to flat rails, positioned around the column head or base. The shear load from the slab is transferred through the studs into the column.



Channel and Bolt Fixings

Ancon offers a wide range of channels and bolts in order to fix stainless steel masonry support, restraints and windposts to structural frames. Cast-in channels and expansion bolts are used for fixing to the edges of concrete floors and beams.



- Masonry Support Systems
- Lintels
- Masonry Reinforcement
- Windposts and Parapet Posts
- Wall Ties and Restraint Fixings
- Channel and Bolt Fixings
- Tension and Compression Systems
- Insulated Balcony Connectors
- Shear Load Connectors
- Punching Shear Reinforcement
- Reinforcing Bar Couplers
- Reinforcement Continuity Systems**
- Stainless Steel Fabrications
- Flooring and Formed Sections
- Refractory Fixings



Ancon Building Products
 President Way, President Park
 Sheffield S4 7UR
 United Kingdom
 Tel: +44 (0) 114 275 5224
 Fax: +44 (0) 114 276 8543
 Email: info@ancon.co.uk
 Visit: www.ancon.co.uk
 Follow on Twitter: @AnconUK

Ancon (Middle East) FZE
 PO Box 17225
 Jebel Ali
 Dubai
 United Arab Emirates
 Tel: +971 (0) 4 883 4346
 Fax: +971 (0) 4 883 4347
 Email: info@ancon.ae
 Visit: www.ancon.ae

Ancon Building Products
 114 Kurrajong Avenue
 Mount Druitt
 Sydney
 NSW 2770
 Australia
 Tel: +61 (0) 2 8808 1111
 Fax: +61 (0) 2 9675 3390
 Email: info@ancon.com.au
 Visit: www.ancon.com.au

Ancon (Schweiz) AG
 Gewerbezone Widalmi 10
 3216 Ried bei Kerzers
 Switzerland
 Tel: +41 (0) 31 750 3030
 Fax: +41 (0) 31 750 3033
 Email: info@ancon.ch
 Visit: www.ancon.ch

Ancon Building Products GesmbH
 Puchgasse 1
 A-1220 Vienna
 Austria
 Tel: +43 (0) 1 259 58 62-0
 Fax: +43 (0) 1 259 58 62-40
 Email: info@ancon.at
 Visit: www.ancon.at

Ancon GmbH
 Bartholomäusstrasse 26
 90489 Nuremberg
 Germany
 Tel: +49 (0) 911 955 1234 0
 Fax: +49 (0) 911 955 1234 9
 Email: info@anconbp.de
 Visit: www.anconbp.de

These products are available from:



© Ancon Building Products 2013



The construction applications and details provided in this literature are indicative only. In every case, project working details should be entrusted to appropriately qualified and experienced persons.

Whilst every care has been exercised in the preparation of this document to ensure that any advice, recommendations or information is accurate, no liability or responsibility of any kind is accepted in respect of Ancon Building Products.

With a policy of continuous product development Ancon Building Products reserves the right to modify product design and specification without due notice.



ISO 9001: 2008
 FM 12226



ISO 14001: 2004
 EMS 505377



OHSAS 18001: 2007
 OHS 548992